



BE-LOK INSTRUMENT FITTINGS  
INC

## DIN 2353 24° Pipe Adapter

100% Factory Tested For Both Crack & Reseal



Engineering Expertise

@ [www.be-lok.com](http://www.be-lok.com)

## Introduction

**BE-LOK INSTRUMENT FITTINGS INC.** A fast-growing manufacturing company spread across an area of 5500 m<sup>2</sup> (Meters Squared). We are having experience and expertise with advanced technology in design, development and production of high-quality fittings and valves for Instrumentation, Hydraulic, Chemical Injection and Oil & Gas Applications.

We are having state of the art manufacturing facility. We use the Latest manufacturing technologies for highest precision and lowest tolerance. Our well-equipped Manufacturing and Testing facilities is most comprehensive, technically advanced and system oriented.

We manufacture all our products in our own manufacturing facilities under strict quality assurance procedure.

Our products are in line with international specification requirements in quality, safety, consistency and reliability apart from the competitive price. We ensure that our products are quality checked before being shipped to our clients' location.

We are recognised by International Quality Management Systems & Certified by ISO 9001:2015, ISO 14001:2015, ISO 45001:2018, PED 2014/68/EU, ASTM F1387-19, Interchangeability Test Report, MSS-SP-99-2016a etc.

As we are having 20% Market in Domestic Areas and have a 80% hold in international market.

# Introduction

In fluid power systems, power is transmitted and controlled through a fluid (liquid or gas) under pressure within an enclosed circuit. In general applications, a fluid may be conveyed under pressure.

Components may be connected through their ports by connections (connectors) and conductors (tubes and hoses). Tubes are rigid conductors; hoses are flexible conductors.

## Foreword

ISO (the International Organization for Standardization) is a worldwide federation of national standards bodies (ISO member bodies). The work of preparing International Standards is normally carried out through ISO technical committees. Each member body interested in a subject for which a technical committee has been established has the right to be represented on that committee. International organizations, governmental and non-governmental, in liaison with ISO, also take part in the work. ISO collaborates closely with the International Electrotechnical Commission (IEC) on all matters of electrotechnical standardization.

International Standards are drafted in accordance with the rules given in the ISO/IEC Directives, Part 2.

The main task of technical committees is to prepare International Standards. Draft International Standards adopted by the technical committees are circulated to the member bodies for voting. Publication as an International Standard requires approval by at least 75 % of the member bodies casting a vote.

Attention is drawn to the possibility that some of the elements of this document may be the subject of patent rights. ISO shall not be held responsible for identifying any or all such patent rights.

ISO 8434-1 was prepared by Technical Committee ISO/TC 131, Fluid power systems, Subcommittee SC 4, Connectors and similar products and components.

This second edition of ISO 8434-1 cancels and replaces ISO 8434-1:1994 and ISO 8434-4:1995, of which it constitutes a technical revision.

ISO 8434 consists of the following parts, under the general title **Metallic tube connections for fluid power and general use**:

- Part 1: 24° cone connectors
- Part 2: 37° flared connectors
- Part 3: O-ring face seal connectors
- Part 6: 60° cone connectors with or without O-ring

### 1 Scope

This part of ISO 8434 specifies the general and dimensional requirements for 24° cone connectors using cutting ring and O-ring seal cone (referred to as DKO) suitable for use with ferrous and non-ferrous tubes with outside diameters from 4 mm to 42 mm inclusive. These connectors are for use in fluid power and general applications within the limits of pressure and temperature specified in this part of ISO 8434.

They are intended for the connection of plain end tubes and hose fittings to ports in accordance with ISO 6149-1, ISO 1179-1 and ISO 9974-1. (See ISO 12151-2 for related hose fitting specification.)

These connectors provide full-flow connections in hydraulic systems operating to the working pressures shown in Table 1. Because many factors influence the pressure at which a system performs satisfactorily, these values are not to be understood as guaranteed minimums. For every application, sufficient testing will need to be conducted and reviewed by both the user and manufacturer to ensure that required performance levels are met.

**NOTE 1:** For new designs in hydraulic fluid power applications, see the requirements given in 9.6. Where the requirements of the application allow for the use of elastomeric seals, connector designs that conform to International Standards and incorporate elastomeric sealing are preferred.

**NOTE 2:** For use under conditions outside the pressure and/or temperature limits specified, see 5.4. This part of ISO 8434 also specifies a performance and qualification test for these connectors.

### 2 Normative references

The following referenced documents are indispensable for the application of this document. For dated references, only the edition cited applies. For undated references, the latest edition of the referenced document (including any amendments) applies.

ISO 48, Rubber, vulcanized or thermoplastic — Determination of hardness (hardness between 10 IRHD and 100 IRHD)

ISO 228-1:2000, Pipe threads where pressure-tight joints are not made on the threads — Part 1: Dimensions, tolerances and designation

ISO 261, ISO general purpose metric screw threads — General plan

ISO 965-1:1998, ISO general-purpose metric screw threads — Tolerances — Part 1: Principles and basic data

ISO 1127, Stainless steel tubes — Dimensions, tolerances and conventional masses per unit length

- ISO 1179-1, Connections for general use and fluid power — Ports and stud ends with ISO 228-1 threads with elastomeric or metal-to-metal sealing — Part 1: Threaded ports
- ISO 1179-2, Connections for general use and fluid power — Ports and stud ends with ISO 228-1 threads with elastomeric or metal-to-metal sealing — Part 2: Heavy-duty (S series) and light-duty (L series) stud ends with elastomeric sealing (type E)
- ISO 1179-4, Connections for general use and fluid power — Ports and stud ends with ISO 228-1 threads with elastomeric or metal-to-metal sealing — Part 4: Stud ends for general use only with metal-to-metal sealing (type B)
- ISO 3304, Plain end seamless precision steel tubes — Technical conditions for delivery ISO 3305, Plain end welded precision steel tubes — Technical conditions for delivery ISO 3601-3:2005, Fluid power systems — O-rings — Part 3: Quality acceptance criteria
- ISO 4759-1:2000, Tolerances for fasteners — Part 1: Bolts, screws, studs and nuts — Product grades A, B and C
- ISO 5598:1985, Fluid power systems and components — Vocabulary
- ISO 6149-1, Connections for hydraulic fluid power and general use — Ports and stud ends with ISO 261 metric threads and O-ring sealing — Part 1: Ports with truncated housing for O-ring seal
- ISO 6149-2, Connections for hydraulic fluid power and general use — Ports and stud ends with ISO 261 metric threads and O-ring sealing — Part 2: Dimensions, design, test methods and requirements for heavy-duty (S series) stud ends
- ISO 6149-3, Connections for hydraulic fluid power and general use — Ports and stud ends with ISO 261 metric threads and O-ring sealing — Part 3: Dimensions, design, test methods and requirements for light-duty (L series) stud ends
- ISO 9227, Corrosion tests in artificial atmospheres — Salt spray tests
- ISO 9974-1, Connections for general use and fluid power — Ports and stud ends with ISO 261 threads with elastomeric or metal-to-metal sealing — Part 1: Threaded ports
- ISO 9974-2, Connections for general use and fluid power — Ports and stud ends with ISO 261 threads with elastomeric or metal-to-metal sealing — Part 2: Stud ends with elastomeric sealing (type E)
- ISO 9974-3, Connections for general use and fluid power — Ports and stud ends with ISO 261 threads with elastomeric or metal-to-metal sealing — Part 3: Stud ends with metal-to-metal sealing (type B)
- ISO 12151-2, Connections for hydraulic fluid power and general use — Hose fittings — Part 2: Hose fittings with ISO 8434-1 and ISO 8434-4 24° cone connector ends with O-rings
- ISO 19879:2005, Metallic tube connections for fluid power and general use — Test methods for hydraulic fluid power connections

### 3. Terms and definitions

For the purposes of this document, the terms and definitions given in ISO 5598 and the following apply.

#### 3.1

##### connector connection

leak-proof device used to connect pipelines (conductors) to one another or to equipment

NOTE : Adapted from ISO 5598:1985, definition 5.2.2.

#### 3.2

##### fastening thread

Terminal thread of a complete connector

#### 3.3

##### run

two principal, axially aligned outlets of a tee or cross

#### 3.4

##### branch

side outlet(s) of a tee or cross

#### 3.5

##### chamfer

removal of a conical portion at the entrance of a thread, used to assist assembly and prevent damage to the start of the thread

#### 3.6

##### face-to-face dimension

distance between the two parallel faces of axially aligned outlets of a connector

#### 3.7

##### face-to-centre dimension

distance from the face of an outlet to the central axis of an angularly disposed outlet

#### 3.8

##### assembly torque

torque to be applied in order to achieve a satisfactory final assembly

#### 3.9

##### maximum working pressure

highest pressure at which the system or part of the system is intended to operate in steady-state conditions

## 4. Materials

### 4.1 General

Figures 1 and 2 show the cross-sections and component parts of typical 24° cone connectors.

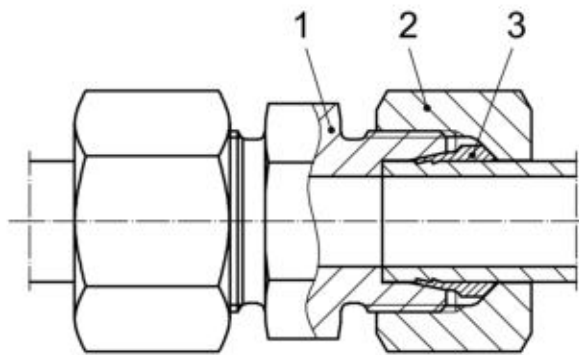

#### Key

- 1 body
- 2 nut
- 3 cutting ring

Figure 1 — Cross-section of typical 24° cone connector with cutting ring

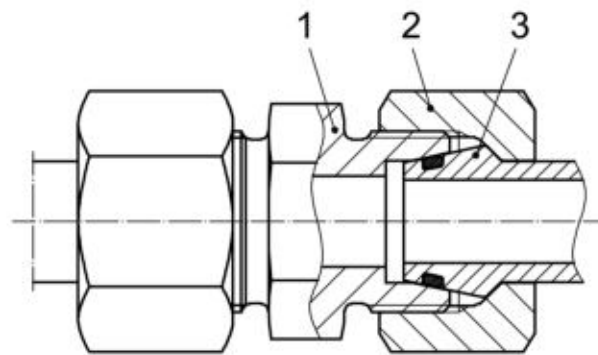

#### Key

- 1 body
- 2 nut
- 3 DKU-end (including O-ring)

Figure 2 — Cross-section of typical 24° cone connector with O-ring seal cone (DKO) end

## 4.2 Connector bodies

Bodies shall be manufactured from carbon steel that will provide the minimum pressure/temperature requirements specified in Clause 5. They shall have characteristics that make them suitable for use with the fluid to be conveyed and that will provide an effective joint.

Weld connector types and weld-on nipples shall be made of materials classified as suitable for welding.

For bodies manufactured from stainless steel and copper alloys, the pressure/temperature ratings need to be defined by the manufacturer.

## 4.3 Nuts

Nuts to be used with carbon steel bodies shall be made of carbon steel, and those for use with stainless steel bodies shall be made of stainless steel, unless otherwise specified.

Nuts to be used with copper alloy bodies shall be made of a material similar to the bodies.

## 4.4 Cutting rings

**4.4.1** The ring material shall be compatible with the fluid to be conveyed and provide an effective joint.

**4.4.2** Steel cutting rings are to be used in combination with other steel connector components and steel tubes.

**4.4.3** Stainless steel cutting rings are to be used in combination with other stainless steel connector components and stainless steel tubes.

**4.4.4** Brass cutting rings are to be used in combination with other brass connector components and copper tubes.

**4.4.5** Other combinations of materials shall be agreed upon between the purchaser and supplier.

## 4.5 O-rings

Unless otherwise specified, for use with petroleum-based hydraulic fluids at the pressure and temperature requirements given in Clause 5 and Table 1, O-rings for use with connectors in accordance with this part of ISO 8434 shall be made of NBR (nitrile) with a hardness of  $(90 \pm 5)$  IRHD, measured in accordance with ISO 48, and shall conform to the dimensions given in Table 5 and shall meet or exceed the O-ring quality acceptance criteria of ISO 3601-3:2005, grade N.

In those cases where the pressure and temperature requirements of this part of ISO 8434 and/or the hydraulic fluid used in the system differ from those specified in Clause 5 and Table 1, the connector manufacturer shall be consulted to ensure that an appropriate O-ring material is selected.



## 5 Pressure/temperature requirements

**5.1** Connectors in conformance with this part of ISO 8434 made of carbon steel shall meet or exceed without leakage the requirements from a vacuum of 6,5 kPa (0,065 bar) absolute pressure to the working pressures given in Tables 1 to 3 when used at temperatures between -40 °C and +120 °C with petroleum-based hydraulic fluids.

**5.2** Connectors complying with this part of ISO 8434 may contain elastomeric seals. Unless otherwise specified, connectors are made and delivered with elastomeric parts giving their specified working temperature range with petroleum-based hydraulic fluids.

The connectors may have a reduced working temperature range or may be completely unsuitable for applications with other fluids. Manufacturers may supply on request connectors with appropriate elastomeric seals meeting the required working temperature range for use with different hydraulic fluids.

**5.3** The connector assembly shall meet or exceed all applicable performance requirements given in Clause 15. Testing shall be conducted at room temperature.

**5.4** For applications under conditions other than the pressure and/or temperature limits given in Tables 1 to 3 and in 5.1 and 5.3, the manufacturer shall be consulted.

**5.5** According to different applications and different pressure ratings, there are three series of connector, designated by

- LL, for extra light-duty,

-L, light-duty, and

- S, heavy-duty.

**NOTE** Ranges of the tube outside diameters and pressure requirements are shown in Tables 1 to 3.

**Table 1 — Working pressures for 24° cone connectors for fluid power and general use**

Series	Tube outside diameter (OD) mm	Cone and cutting ring connection			ISO 6149-2 or ISO 6149-3 stud end		
		Thread	Maximum working pressure a		Thread	Maximum working pressure a	
			MPa	(bar b)		MPa	(bar b)
LL	4	M8 x 1	10	(100)	-	-	-
	5	M10 x 1	10	(100)	-	-	-
	6	M10 x 1	10	(100)	-	-	-
	8	M12 x 1	10	(100)	-	-	-
L	6	M12 x 1,5	25	(250)	M10 x 1	25	(250)
	8	M14 x 1,5	25	(250)	M12 x 1,5	25	(250)
	10	M16 x 1,5	25	(250)	M14 x 1,5	25	(250)
	12	M18 x 1,5	25	(250)	M16 x 1,5	25	(250)
	15	M22 x 1,5	25	(250)	M18 x 1,5	25	(250)
	18	M26 x 1,5	16	(160)	M22 x 1,5	16	(160)
	22	M30 x 2	16	(160)	M27 x 2	16	(160)
	28	M36 x 2	10	(100)	M33 x 2	10	(100)
	35	M45 x 2	10	(100)	M42 x 2	10	(100)
42	M52 x 2	10	(100)	M48 x 2	10	(100)	
S	6	M14 x 1,5	63	(630)	M12 x 1,5	63	(630)
	8	M16 x 1,5	63	(630)	M14 x 1,5	63	(630)
	10	M18 x 1,5	63	(630)	M16 x 1,5	63	(630)
	12	M20 x 1,5	63	(630)	M18 x 1,5	63	(630)
	16	M24 x 1,5	40	(400)	M22 x 1,5	40	(400)
	20	M30 x 2	40	(400)	M27 x 2	40	(400)
	25	M36 x 2	40	(400)	M33 x 2	40	(400)
	30	M42 x 2	25	(250)	M42 x 2	25	(250)
	38	M52 x 2	25	(250)	M48 x 2	25	(250)
For higher pressure ratings and for dynamic conditions, the manufacturer shall be consulted.							
a With a design factor of 4 to 1.							
b 1 bar = 105 N/m <sup>2</sup> = 105 Pa = 0,1 MPa.							

Table 2 — Working pressures for 24° cone connectors, for general use only

Series	Tube OD mm	Cone and cutting ring connection		ISO 9974 stud end						ISO 1179 stud end				
		Thread	Maximum working pressure <sup>a</sup>		Thread	Maximum working pressure <sup>a</sup>				Thread	Maximum working pressure <sup>a</sup>			
			MPa	(bar)		ISO 9974-2 (type E) <sup>b</sup>		ISO 9974-3 (type B) <sup>c</sup>			ISO 1179-2 (type E) <sup>b</sup>		ISO 1179-4 (type B) <sup>c</sup>	
					MPa	(bar)	MPa	(bar)		MPa	(bar)	MPa	(bar)	
LL	4	M8 × 1	10	(100)	M8 × 1	—	—	10	(100)	G 1/8 A	—	—	10	(100)
	5	M10 × 1	10	(100)	M8 × 1	—	—	10	(100)	—	—	—	—	—
	6	M10 × 1	10	(100)	M10 × 1	—	—	10	(100)	—	—	—	—	—
	8	M12 × 1	10	(100)	M10 × 1	—	—	10	(100)	—	—	—	—	—
L	6	M12 × 1,5	25	(250)	M10 × 1	25	(250)	25	(250)	G 1/8 A	25	(250)	25	(250)
	8	M14 × 1,5	25	(250)	M12 × 1,5	25	(250)	25	(250)	G 1/4 A	25	(250)	25	(250)
	10	M16 × 1,5	25	(250)	M14 × 1,5	25	(250)	25	(250)	G 1/4 A	25	(250)	25	(250)
	12	M18 × 1,5	25	(250)	M16 × 1,5	25	(250)	25	(250)	G 3/8 A	25	(250)	25	(250)
	15	M22 × 1,5	25	(250)	M18 × 1,5	25	(250)	25	(250)	G 1/2 A	25	(250)	25	(250)
	18	M26 × 1,5	16	(160)	M22 × 1,5	16	(160)	16	(160)	G 1/2 A	16	(160)	16	(160)
	22	M30 × 2	16	(160)	M26 × 1,5	16	(160)	16	(160)	G 3/4 A	16	(160)	16	(160)
	28	M36 × 2	10	(100)	M33 × 2	10	(100)	10	(100)	G 1 A	10	(100)	10	(100)
	35	M45 × 2	10	(100)	M42 × 2	10	(100)	10	(100)	G 1 1/4 A	10	(100)	10	(100)
	42	M52 × 2	10	(100)	M48 × 2	10	(100)	10	(100)	G 1 1/2 A	10	(100)	10	(100)
S	6	M14 × 1,5	63	(630)	M12 × 1,5	63	(630)	40	(400)	G 1/4 A	63	(630)	40	(400)
	8	M16 × 1,5	63	(630)	M14 × 1,5	63	(630)	40	(400)	G 1/4 A	63	(630)	40	(400)
	10	M18 × 1,5	63	(630)	M16 × 1,5	63	(630)	40	(400)	G 3/8 A	63	(630)	40	(400)
	12	M20 × 1,5	63	(630)	M18 × 1,5	63	(630)	40	(400)	G 3/8 A	63	(630)	40	(400)
	16	M24 × 1,5	40	(400)	M22 × 1,5	40	(400)	40	(400)	G 1/2 A	40	(400)	40	(400)
	20	M30 × 2	40	(400)	M27 × 2	40	(400)	40	(400)	G 3/4 A	40	(400)	40	(400)
	25	M36 × 2	40	(400)	M33 × 2	40	(400)	25	(250)	G 1 A	40	(400)	25	(250)
	30	M42 × 2	25	(250)	M42 × 2	25	(250)	16	(160)	G 1 1/4 A	25	(250)	16	(160)
	38	M52 × 2	25	(250)	M48 × 2	25	(250)	16	(160)	G 1 1/2 A	25	(250)	16	(160)

For higher pressure ratings and for dynamic conditions, the manufacturer shall be consulted.

<sup>a</sup> With a design factor of 4 to 1.

<sup>b</sup> Type E with elastomeric sealing.

<sup>c</sup> Type B with metal-to-metal sealing.

**Table 3 — Working pressures for 24° cone weld-on nipples with various tube wall thicknesses**

Series	Tube OD	Maximum working pressure											
		10 MPa (100 bar)		16 MPa (160 bar)		25 MPa (250 bar)		31,5 MPa (315 bar)		40 MPa (400 bar)		63 MPa (630 bar)	
		Tube ID	T	Tube ID	T	Tube ID	T	Tube ID	T	Tube ID	T	Tube ID	T
L	6	3	1,5	3	1,5	3	1,5						
	8	5	1,5	5	1,5	5	1,5						
	10	7	1,5	7	1,5	7	1,5						
	12	8	2	8	2	8	2						
	15	10	2,5	10	2,5	10	2,5						
	18	13	2,5	13	2,5								
	22	17	2,5	17	2,5								
	28	23	2,5										
	35	29	3										
	42	36	3										
S	6	2,5	1,75	2,5	1,75	2,5	1,75	2,5	1,75	2,5	1,75	2,5	1,75
	8	4	2	4	2	4	2	4	2	4	2	4	2
	10	6	2	6	2	6	2	6	2	6	2	5	2,5
	12	8	2	8	2	8	2	8	2	7	2,5	6	3
	16	11	2,5	11	2,5	11	2,5	11	2,5	10	3		
	20	14	3	14	3	14	3	14	3	12	4		
	25	19	3	19	3	19	3	17	4	16	4,5		
	30	24	3	24	3	22	4						
	38	32	3	32	3	28	5						
For pressure and/or temperature applications outside those given in this part of ISO 8434, the manufacturer shall be consulted.													
ID interior diameter													
T tube wall thickness													

Dimensions in millimetres

## 6 Designation of connectors

- 6.1 Connectors shall be designated by an alphanumeric code to facilitate ordering. They shall be designated by the word "Connector" followed by ISO 8434-1, followed by a spaced hyphen, then the connector style letter symbols (see 6.2), followed by a spaced hyphen, then the series letter(s) (see 5.5), immediately followed by the outside diameter of the tube with which they are to be connected. For weld nipples, a multiplication sign (x) shall then follow, then the tube wall thickness. There shall be no spaces on either side of the multiplication symbol. For stud ends (connector ends), another spaced hyphen followed by the thread designation of the stud end and the sealing type shall be added.
- 6.2 The letter symbol designation of the connector style shall have three parts: the connection end type, immediately followed by the shape of the connector and by the indication that a complete connector is ordered.
- 6.3 Tube ends are assumed and thus do not need to be included in the code. However, if another type of end is involved, it shall be designated.
- 6.4 Reducing connectors and reducing elbows shall be designated by specifying the larger tube end first.
- 6.5 Stud connectors (see Figures 3 and 4) shall be designated by specifying the tube end first, then the thread size for the stud end with the sealing type letter.
- 6.6 For tee connectors, the order of designation of the connection ends shall be from larger to smaller on the run, followed by the branch end.
- 6.7 For cross connectors, the order of designation of the connection ends shall be from left to right, followed by top to bottom, with the larger ends on the left and at the top.
- 6.8 If the connector has a tube union connection, it shall be designated first. Then the designation shall proceed clockwise.
- 6.9 The following letter symbols shall be used.

Connection end type	Symbol	Shape	Symbol
Bulkhead	BH	Straight	S
Swivel with O-ring	SWO	Elbow	E
Weld-on/weld-in	WD	45° elbow	E45
Stud	SD	Tee	T
Reducer	RD	Run tee	RT
		Branch tee	BT
		Cross	K

## Component type

Component type	Symbol
Nut	N
Cutting ring	CR
Locknut	LN
Nipple	NP
Plug	PL

## Completeness indication

Completeness indication	Symbol
Complete connector	C

## Stud end sealing types

Stud end sealing types	Symbol
Metal-to-metal sealing	B
Elastomeric sealing	E
O-ring sealing	F

6.10 Examples of compression connectors and designations are given below and in Figures 3 to 5.

**EXAMPLE 1** A stud straight connector, including O-ring without cutting ring and nut, with a heavy-duty stud connection end having an M18 x 1,5 thread in accordance with ISO 6149-2, to be connected to a 12 mm OD tube, is designated for ordering as follows:

**Connector ISO 8434-1 - SDS - S12 x M18 - F**

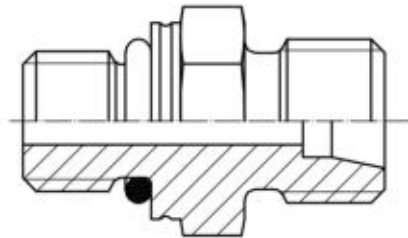

Figure 3 — Stud straight connector (SDS) with stud end as per ISO 6149-2 (sealing type F)

**EXAMPLE 2** A complete stud straight connector, including O-ring with cutting ring and nut, with a heavy-duty stud connection end having an M18 x 1,5 thread in accordance with ISO 6149-2, to be connected to a 12 mm OD tube, is designated for ordering as follows:

**Connector ISO 8434-1 - SDSC - S12 x M18 - F**

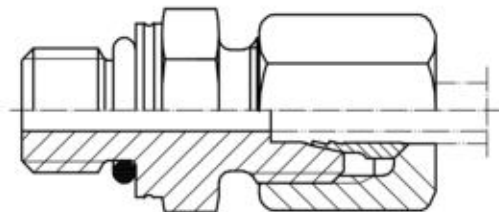

Figure 4 — Complete stud straight connector (SDSC) with stud end as per ISO 6149-2 (sealing type F)

EXAMPLE 3 A complete weld-on nipple, including O-ring, with a light-duty connection end, to be welded to a 15 mm OD tube having a wall thickness of 1,5 mm, is designated for ordering as follows:

### Connector ISO 8434-1 - WDNP - L15 x 1,5

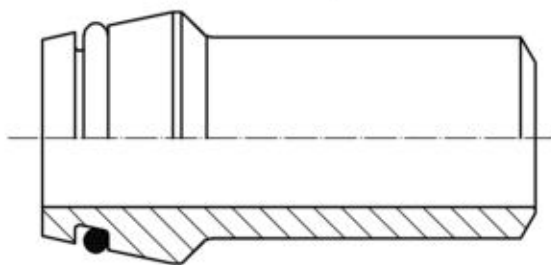

Figure 5 — Weld-on nipple with O-ring (WDNP)

## 7 Requirements for tubes

Carbon steel tubes shall comply with delivery condition R37 NBK, as specified in ISO 3304 (cold-drawn and normalized) or ISO 3305 (cold-drawn and normalized). Stainless steel tubes shall be in accordance with ISO 1127 (annealed).

## 8 Across-flats dimensions and tolerances

8.1 For sizes up to and including 24 mm, tolerances for across-flats dimensions for forgings shall be 0 -0,8 mm, and for sizes larger than 24 mm, they shall be  $\pm 0$  mm.

8.2 Hex tolerances across flats shall be in accordance with ISO 4759-1:2000, product grade B. Minimum across-corner hex dimensions are 1,092 times the width across flats. The minimum side flat is 0,43 times the nominal width across flats. Unless otherwise specified or shown, hex corners shall be chamfered  $10^\circ$  to  $30^\circ$  to a diameter equal to the width across flats, with a tolerance of 0 -0,4 mm. The dimensions across flats for nuts and on the bodies of the connectors shall be those given in Table 5 and Tables 9 to 21.

## 9 Design

### 9.1 Connectors

The connectors shall conform to the requirements given in Figures 6 to 25 and Tables 4 to 22. They shall be designed so that resistance to flow is reduced to a minimum.

### 9.2 Dimensions

Dimensions specified apply to finished parts, including any plating or other treatments. The tolerance value for all dimensions not otherwise limited shall be  $\pm 0,4$  mm. The sealing seats of connectors shall be concentric with straight thread pitch diameters within 0,25 mm full indicator reading (FIR).

### 9.3 Passage tolerances

Where passages in straight connectors are machined from opposite ends, the offset at the meeting point shall not exceed 0,4 mm. No cross-sectional area at a junction of passages shall be less than that of the smallest specified passage.

## 9.4 Angular tolerances

Angular tolerance on axes of ends of elbows, tees and crosses shall be  $\pm 2,5^\circ$  for connectors for tube sizes 10 mm and smaller, and  $\pm 1,5^\circ$  for all larger sizes.

## 9.5 Contour details

Details of contour shall be chosen by the manufacturer provided the dimensions given in Tables 4 to 22 are maintained. Wrench flats on elbows and tees shall conform to the dimensions given in the relevant tables. Abrupt reduction of a section shall be avoided. Junctions of small external sections and adjoining sections that are relatively heavy shall be blended by means of ample fillets.

## 9.6 Ports and stud ends

These connectors are intended for the connection of plain end tubes and hose connectors to ports in accordance with ISO 6149-1, ISO 1179-1 or ISO 9974-1. For new designs in hydraulic fluid power applications, only ports and stud ends in accordance with the relevant parts of ISO 6149 shall be used.

## 9.7 Stud end sealing

Unless otherwise agreed upon between the supplier and purchaser, seals for stud ends and weld nipples shall be included in the delivery.

## 10 Screw threads

### 10.1 Cone ends and nuts

The screw threads on the cone ends and the nuts of the connectors shall be ISO metric screw threads in accordance with ISO 261, tolerance grade 6g, in accordance with ISO 965-1:1998.

Threads shall be chamfered at the face of the connector to an included angle of  $45^\circ$ . The diameter of the chamfer shall be equal to the minor diameter of the thread, with a tolerance of  ${}^0_{-0,4}$  mm.

### 10.2 Stud ends (connection ends)

The thread for stud ends (connection ends) of connectors shall be chosen from ISO 228-1:2000, Class A, or ISO 261, tolerance grade 6g, in accordance with ISO 965-1:1998. The dimensions of the stud ends shall be in accordance with Tables 11 to 13 and the relevant stud end standards.

**NOTE** Parallel threads require an undercut with a sealing washer, O-ring or similar device to ensure a leak-proof joint, unless the stud end undercut is designed for metal-to-metal sealing.

## 11 Manufacture

### 11.1 Construction

Carbon steel connectors made from multiple components shall be bonded together with materials having a melting point of not less than 1 000 °C.



## 11.2 Workmanship

The connectors shall be free from defects such as cracks and porosity and shall be deburred. Sharp edges shall be removed on the outside. All machined surfaces shall have a material removal rate surface roughness value of  $MRR_{Ramax} \leq 6,3 \mu\text{m}$ , except where otherwise specified in the figures.

## 11.3 Finish

The external surface and threads of all carbon steel parts shall be plated or coated with a suitable material that passes a 72 h neutral salt spray test in accordance with ISO 9227, unless otherwise agreed upon by the manufacturer and the user. Any appearance of red rust during the salt spray test on any area, excepting the following, shall be considered failure:

- all internal fluid passages;
- edges, such as hex points, serrations and crests of threads, where there may be mechanical deformation of the plating or coating typical of mass-produced parts or shipping effects;
- areas where there is mechanical deformation of the plating or coating caused by crimping, flaring, bending and other post-plate metal-forming operations;
- areas where the parts are suspended or affixed in the test chamber, where condensate can accumulate. Internal fluid passages shall be protected from corrosion during storage. Weld components shall be protected from corrosion by an oil film or phosphate coating, or by other means that do not negatively affect weldability.

Parts manufactured in accordance with this part of ISO 8434 shall not be cadmium-plated.

## 11.4 Corners

Unless otherwise noted, all sharp corners shall be broken to 0,15 mm maximum.

## 12 Assembly instruction

The assembly of the connectors with the connecting tubes shall be carried out without external loads.

The manufacturer shall draw up assembly instructions for the use of the connectors. These instructions shall include at least the following:

- details relating to material and quality of suitable tubes;
- details concerning the preparation of the selected tube;
- instructions regarding the assembly of the connector, such as the number of wrenching turns or assembly torque;
- recommendations regarding the tools to be used for assembly.

## 13 Procurement information

The following information should be supplied by the purchaser when making an inquiry or placing an order:

- description of connector;
- material of connector;
- material and size of tube;
- fluid to be conveyed;
- working pressure;
- fluid working temperature range;
- ambient temperature range.

## 14 Marking of components

Connector bodies, cutting rings, weld-on nipples and nuts shall be permanently marked with the manufacturer's name, trademark or code identifier unless otherwise agreed by the user and manufacturer. Nuts shall also be marked with the connector size and series.

## 15 Performance and qualification test

### 15.1 General

The connectors shall meet or exceed the pressure requirements given in Table 1 when tested in accordance with this clause.

### 15.2 Repeated assembly test

The connectors shall pass a repeated assembly test in accordance with ISO 19879:2005, Clause 5

### 15.3 Proof test

The connectors shall pass a proof test in accordance with ISO 19879:2005, Clause 7.

### 15.4 Burst pressure test

The connectors shall pass a burst pressure test in accordance with ISO 19879:2005, Clause 8.

### 15.5 Cyclic endurance (impulse) test

The connectors shall pass a cyclic endurance test in accordance with ISO 19879:2005, Clause 9. The cyclic endurance test with vibration specified in ISO 19879 may be used in place of separate cyclic endurance and vibration tests.

### 15.6 Vibration test

The connectors shall pass a vibration test in accordance with ISO 19879:2005, Clause 12. The cyclic endurance test with vibration specified in ISO 19879 may be used in place of separate cyclic endurance and vibration tests.

## 15.7 Leakage (gas) test

15.7.1 Three samples shall be tested to confirm that they are capable of withstanding the test procedure described in 15.7.2 to 15.7.4.

15.7.2 Install the samples in a basin filled with water.

15.7.3 After installation, fill the samples with air, nitrogen or helium up to a pressure of 10 MPa (100 bar).

15.7.4 Hold the samples at pressure for 3 min and watch for the presence of rising bubbles.

15.7.5 The samples shall be capable of withstanding the pressure of 10 MPa (100 bar) for 3 min without leakage, indicated by rising bubbles.

15.7.6 The test fluid (air, nitrogen or helium) shall be documented on the test report.

## 15.8 Overtightening test

### 15.8.1 Connectors with cutting rings

15.8.1.1 For each size, three samples each of the cutting ring connection ends shall be tested.

15.8.1.2 After tightening the cutting ring connection end from finger-tight position plus 1,5 turns, the connection shall be capable of withstanding an overtightening by a 90° turn with no indication of the following failures:

- the nut cannot be removed and swivels freely after breakaway;
- visible cracks or severe deformation appear that would render the connector component unusable.

### 15.8.2 Connectors with O-ring seal cone (DKO)

For each size, three samples of the O-ring seal cone (DKO) ends shall be tested in accordance with ISO 19879.

## 16 Identification statement (reference to this part of ISO 8434)

Use the following statement in test reports, catalogues and sales literature when electing to comply with this part of ISO 8434:

“Dimensions and design for 24° cone connectors in accordance with ISO 8434-1, Metallic tube connections for fluid power and general use — Part 1: 24° cone connectors.”

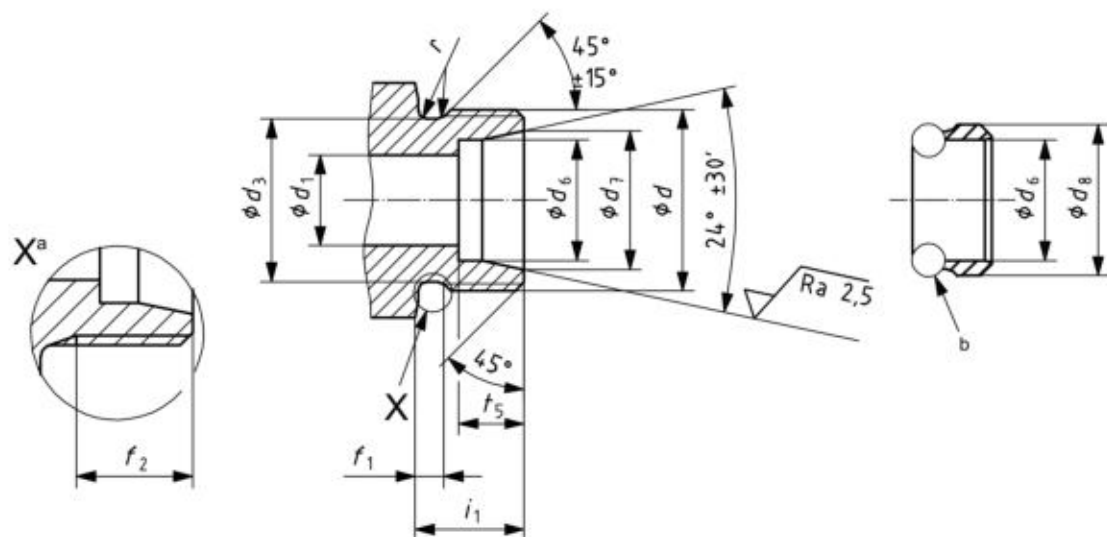

NOTE For dimension values, see Table 4.

- a. Optional thread run-out.
- b. Interface at the option of the manufacturer.

Figure 6 — Cutting ring (CR) and 24° cone end

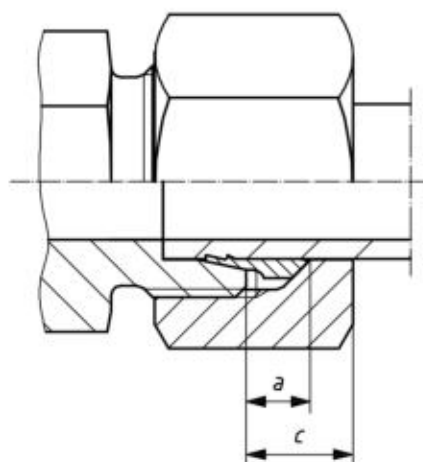

NOTE For dimension values, see Table 4.

Figure 7 — Assembly

Table 4 — Dimensions of cone end and cutting ring

Series	Tube OD	Thread d	i1 ± 0,2	t5 +0,3 0	d1		d <sub>e</sub>		d7 +0,1 0	d8 max	a a		d <sub>3</sub> 0 -0,2	f <sub>1</sub> +0,3 0	f <sub>2</sub> min.	r ± 0,2	c <sup>a</sup> =
					nom	tol.	B11 <sup>b</sup> +0,1 0	nom.			tol.						
LL	4	M8 × 1	8	4	3	± 0,1	4	—	5	6,5	3,5	+0,1 0	6,4	2	6	0,8	6
	5	M10 × 1	8	5,5	3,5	± 0,1	5	—	6,5	8,5	4		8,4	2	6	0,8	6
	6	M10 × 1	8	5,5	4,5	± 0,1	6	—	7,5	8,5	4		8,4	2	6	0,8	6
	8	M12 × 1	9	5,5	6	± 0,1	8	—	9,5	10,5	4		10,4	2	8	0,8	6
L	6	M12 × 1,5	10	7	4	± 0,1	6	—	8,1	10	5	+0,1 0	9,7	3	7,5	1	8
	8	M14 × 1,5	10	7	6	± 0,1	8	—	10,1	12	5		11,7	3	7,5	1	8
	10	M16 × 1,5	11	7	8	± 0,2	10	—	12,3	14	5	+0,15 0	13,7	3	8,5	1	8
	12	M18 × 1,5	11	7	10	± 0,2	12	—	14,3	16	5		15,7	3	8,5	1	8
	15	M22 × 1,5	12	7	12	± 0,2	15	—	17,3	20	5		19,7	3	9,5	1	8
	18	M26 × 1,5	12	7,5	15	± 0,2	18	—	20,3	24	5,5		23,7	3	9,5	1	9
	22	M30 × 2	14	7,5	19	± 0,2	22	—	24,3	27	6	+2 0	27	4	10,5	1,2	9
	28	M36 × 2	14	7,5	24	± 0,2	28	—	30,3	33	6		33	4	10,5	1,2	9
	35	M45 × 2	16	10,5	30	± 0,3	—	35,3	38	42	7		42	4	12,5	1,2	11
	42	M52 × 2	16	11	36	± 0,3	—	42,3	45	49	7		49	4	12,5	1,2	12
S	6	M14 × 1,5	12	7	4	± 0,1	6	—	8,1	12	5	+1,5 0	11,7	3	9,5	1	8
	8	M16 × 1,5	12	7	5	± 0,2	8	—	10,1	14	5		13,7	3	9,5	1	8
	10	M18 × 1,5	12	7,5	7	± 0,2	10	—	12,3	16	5		15,7	3	9,5	1	9
	12	M20 × 1,5	12	7,5	8	± 0,2	12	—	14,3	18	5		17,7	3	9,5	1	9
	16	M24 × 1,5	14	8,5	12	± 0,2	16	—	18,3	22	5		21,7	3	11,5	1	10
	20	M30 × 2	16	10,5	16	± 0,2	20	—	22,9	27	6,5	+2 0	27	4	12,5	1,2	11
	25	M36 × 2	18	12	20	± 0,2	25	—	27,9	33	6,5		33	4	14,5	1,2	12
	30	M42 × 2	20	13,5	25	± 0,2	30	—	33	39	7		39	4	16,5	1,2	13
38	M52 × 2	22	16	32	± 0,3	—	38,3	41	49	7,5	49		4	18,5	1,2	15	

<sup>a</sup> Dimensions a and c are measured when fully tightened.

<sup>b</sup> Tolerances in accordance with ISO 286-2.

Dimensions in millimetres

Figure 8 — Tube nut (N)

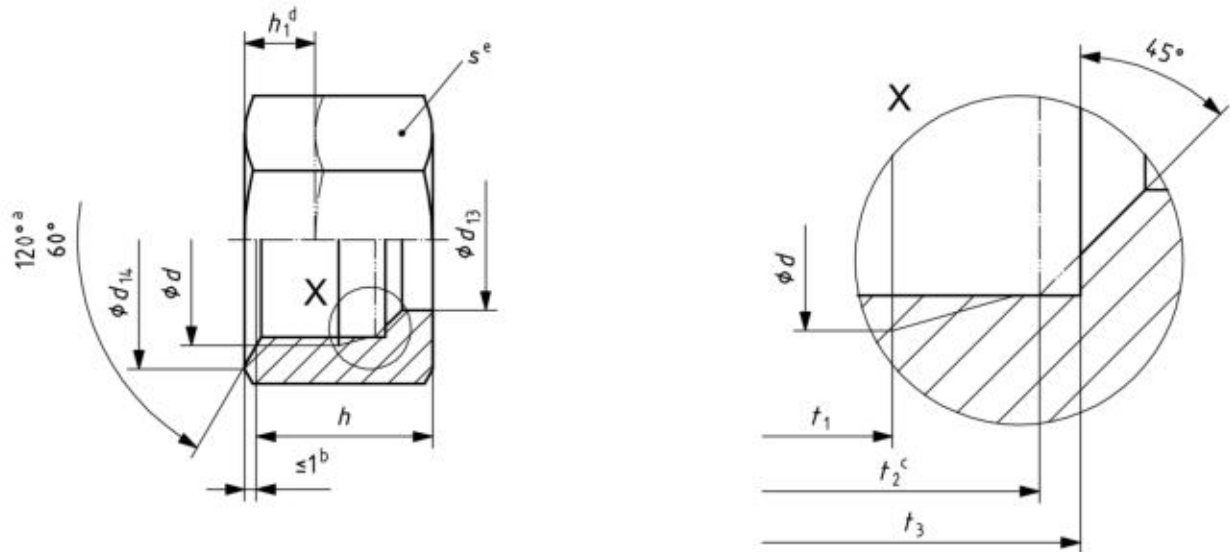

- a Internal chamfer angle.
- b Permitted for cold-formed nuts.
- c Alternative full chamfer.
- d For optional machining of shoulders
- e Width across flats.

Dimensions in millimetres

Table 5 — Dimensions of tube nut

Series	Tube OD	Thread d	d <sub>13</sub>		d <sub>14</sub> <sup>a</sup> ref.	t <sub>1</sub> min.	h +0,5 -0,2	h <sub>1</sub> <sup>a</sup> ±1	S	t <sub>2</sub> 0 +0,2	t <sub>3</sub> 0 +0,2
			B11b	+0,1 0							
LL	4	M8 × 1	4	—	9,8	5	11	3,5	10	7,5	8
	5	M10 × 1	5	—	11,8	5,5	11,5	3,5	12	7,8	8,5
	6	M10 × 1	6	—	11,8	5,5	11,5	3,5	12	8,2	8,5
	8	M12 × 1	8	—	13,8	6	12	3,5	14	8,7	9
L	6	M12 × 1,5	6	—	13,8	7	14,5	4	14	10	10,5
	8	M14 × 1,5	8	—	16,8	7	14,5	4	17	10	10,5
	10	M16 × 1,5	10	—	18,8	8	15,5	4	19	11	11,5
	12	M18 × 1,5	12	—	21,8	8	15,5	5	22	11	11,5
	15	M22 × 1,5	15	—	26,8	8,5	17	5	27	11,5	12,5
	18	M26 × 1,5	18	—	31,8	8,5	18	5	32	11,5	13
	22	M30 × 2	22	—	35,8	9,5	20	7	36	13,5	14,5
	28	M36 × 2	28	—	40,8	10	21	7	41	14	15
	35	M45 × 2	—	35,3	49,8	12	24	8	50	16	17
	42	M52 × 2	—	42,3	59,6	12	24	8	60	16	17
S	6	M14 × 1,5	6	—	16,8	8,5	16,5	5	17	11	12,5
	8	M16 × 1,5	8	—	18,8	8,5	16,5	5	19	11	12,5
	10	M18 × 1,5	10	—	21,8	8,5	17,5	5	22	11	12,5
	12	M20 × 1,5	12	—	23,8	8,5	17,5	5	24	11	12,5
	16	M24 × 1,5	16	—	29,8	10,5	20,5	6	30	13	14,5
	20	M30 × 2	20	—	35,8	12	24	8	36	15,5	17
	25	M36 × 2	25	—	45,8	14	27	9	46	17	19
	30	M42 × 2	30	—	49,8	15	29	10	50	18	20
	38	M52 × 2	—	38,3	59,6	17	32,5	10	60	19,5	22,5

<sup>a</sup> Dimensions d<sub>14</sub> et h<sub>1</sub> are for optional machining of shoulders.

<sup>b</sup> Tolerances in accordance with ISO 286-2.

Dimensions in millimetres

Figure 9 - Weld-on Nipple (WDNP)

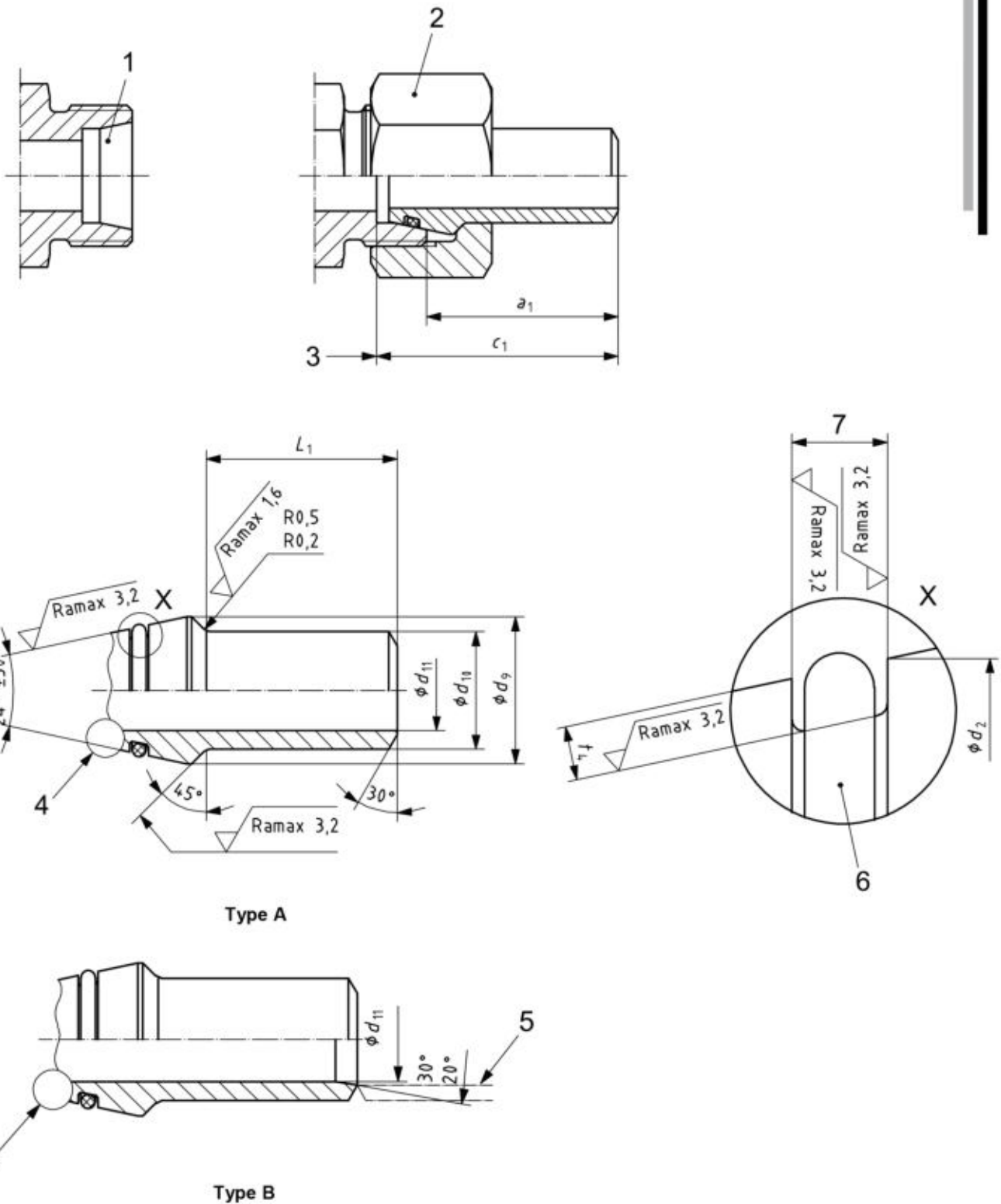

Type A

Type B

Key

- |  |   |
|--|---|
| 1 24° cone end (see Figure 6)              | 5 Tube inside diameter                                  |
| 2 tube nut (see Figure 8)                  | 6 O-ring  |
| 3 tube stop                                | 7 width of O-ring groove, as chosen by the manufacturer |
| 4 interface, as chosen by the manufacturer |   |



Table 6 — Dimensions of weld-on nipple

Series	Tube OD	d <sub>10</sub> ±0,1	d <sub>11</sub> <sup>a</sup> +0,20 -0,05	d <sub>9</sub>		d <sub>2</sub> max.	L <sub>1</sub> ±0,2	C <sub>1</sub> ±1	a <sub>1</sub> ±1	t <sub>4</sub> ±0,1
				min.	max.					
L	6	6	3	9	11	7,8	19	32	25	1,1
	8	8	5	11	13	9,8	19	32	25	1,1
	10	10	7	14	16	12	20	33,5	26	1,1
	12	12	8	16	18	14	20	33,5	26	1,1
	15	15	10	18	20	17	22	35	28	1,5
	18	18	13	21	24	20	23	37	29,5	1,5
	22	22	17	25	27	24	24,5	39,5	32	1,5
	28	28	23	31	33	30	27,5	42,5	35	1,5
	35	35	29	40	42	37,7	30,5	49,5	39	1,9
	42	42	36	47	49	44,7	30,5	50	39	1,9
S	6	6	2,5	9	11	7,8	19	32	25	1,1
	8	8	4	11	13	9,8	19	32	25	1,1
	10	10	6	14	16	12	20	33,5	26	1,1
	12	12	8	16	18	14	20	33,5	26	1,1
	16	16	11	20	22	18	26	40,5	32	1,5
	20	20	14	24	27	22,6	28,5	47	36,5	1,8
	25	25	19	29	33	27,6	33,5	53,5	41,5	1,8
	30	30	24	35	39	32,7	35,5	57,5	44	1,8
	38	38	32	43	49	40,7	39,5	64,5	48,5	1,8

NOTE The dimensions given in this table are for the lowest working pressures given in Table 3. See Table 3 for tube inside diameters and wall thicknesses required for other working pressures.

<sup>a</sup> Maximum permissible inside diameter of type A weld-on nipples. If the inside diameter of a tube is larger than  $d_2 + 0,5$  mm, use of type B weld-on nipples is recommended.

Dimensions in millimetres

Table 7 — Dimensions of O-ring

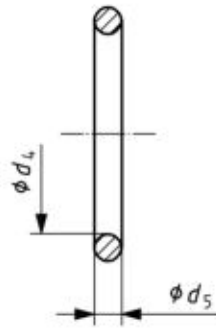

Figure 10 — O-ring

Series	Tube OD	Inside diameter $d_4$		Cross-section $d_5$	
		nom.	tol.	nom.	tol.
L	6	4	$\pm 0,14$	1,5	$\pm 0,08$
	8	6	$\pm 0,14$	1,5	$\pm 0,08$
	10	7,5	$\pm 0,16$	1,5	$\pm 0,08$
	12	9	$\pm 0,16$	1,5	$\pm 0,08$
	15	12	$\pm 0,18$	2	$\pm 0,09$
	18	15	$\pm 0,18$	2	$\pm 0,09$
	22	20	$\pm 0,22$	2	$\pm 0,09$
	28	26	$\pm 0,22$	2	$\pm 0,09$
	35	32	$\pm 0,31$	2,5	$\pm 0,09$
	42	38	$\pm 0,31$	2,5	$\pm 0,09$
S	6	4	$\pm 0,14$	1,5	$\pm 0,08$
	8	6	$\pm 0,14$	1,5	$\pm 0,08$
	10	7,5	$\pm 0,16$	1,5	$\pm 0,08$
	12	9	$\pm 0,16$	1,5	$\pm 0,08$
	16	12	$\pm 0,18$	2	$\pm 0,09$
	20	16,3	$\pm 0,18$	2,4	$\pm 0,09$
	25	20,3	$\pm 0,22$	2,4	$\pm 0,09$
	30	25,3	$\pm 0,22$	2,4	$\pm 0,09$
	38	33,3	$\pm 0,31$	2,4	$\pm 0,09$

All designs shall meet the performance requirements of this part of ISO 8434 using O-rings to these dimensions. O-rings of other sizes may be used as long as the sealing function is ensured.

Dimensions in millimetres

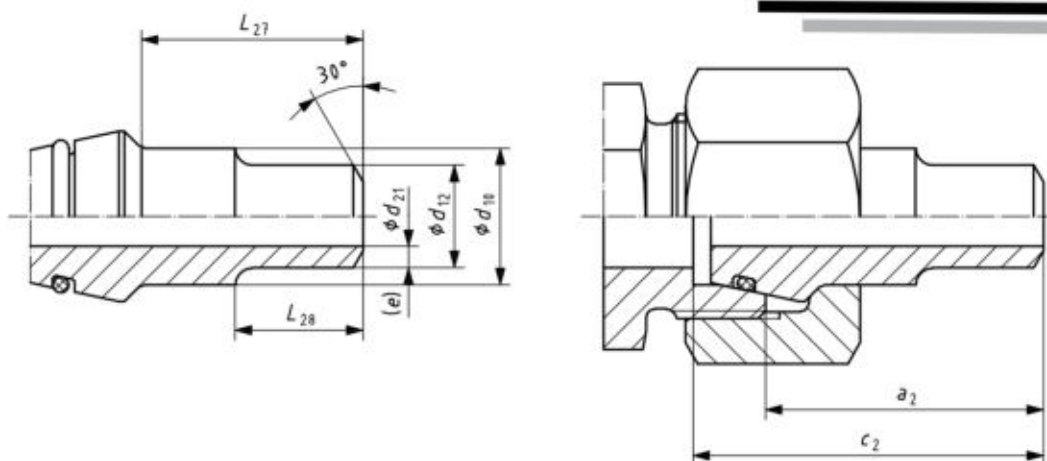

Figure 11 — Weld-on reducing nipple (WDRDNP)

Table 8 — Dimensions of L and S series weld-on reducing nipples

Series	Tube OD		d <sub>21</sub>		(e)	L <sub>27</sub> ±0,2	c <sub>2</sub> ± 1	a <sub>2</sub> ± 1	L <sub>28</sub> ± 0,2
	d <sub>10</sub> ±0,1	d <sub>12</sub> ±0,1	nom.	tol.					
L	8	6	3	± 0,1	1,5	19	31,5	24,5	12
	10	8	5	± 0,1	1,5	20	33,5	26	12
	12	10	7	± 0,2	1,5	20	33,5	26	14
	18	15	12	± 0,2	1,5	23	37	29,5	16
	22	15	12	± 0,2	1,5	24,5	39,5	32	18
		18	15	± 0,2	1,5				
	28	15	12	± 0,2	1,5	27,5	42,5	35	20
		18	15	± 0,2	1,5				
		22	18	± 0,2	2				
	35	15	12	± 0,2	1,5	30,5	49,5	39	25
		18	15	± 0,2	1,5				
		22	18	± 0,2	2				
		28	24	± 0,2	2				
	42	15	12	± 0,2	1,5	30,5	50	39	28
		18	15	± 0,2	1,5				
22		18	± 0,2	2					
28		24	± 0,2	2					
35		31	± 0,3	2					

Dimensions in millimetres

Table 8 — Dimensions of L and S series weld-on reducing nipples (continued)

Series	Tube OD		d <sub>21</sub>		(e)	L <sub>27</sub> ±0,2	c <sub>2</sub> ± 1	a <sub>2</sub> ± 1	L <sub>28</sub> ± 0,2
	d <sub>10</sub>	d <sub>12</sub>	nom.	tol.					
	±0,1	±0,1							
S	8	6	2	± 0,1	2	19	32	25	12
	10	8	3	± 0,1	2,5	20	33,5	26	12
		6	2	± 0,1	2				
	12	10	4	± 0,1	3	20	33,5	26	14
		8	3	± 0,1	2,5				
		6	2	± 0,1	2				
	16	12	8	± 0,2	2	26	40,5	32	15
		10	6	± 0,1	2				
		8	5	± 0,1	1,5				
		6	3	± 0,1	1,5				
	20	16	10	± 0,2	3	28,5	47	36,5	17
		12	8	± 0,2	2				
		10	6	± 0,1	2				
		8	5	± 0,1	1,5				
		6	3	± 0,1	1,5				
	25	20	13	± 0,2	3,5	33,5	53,5	41,5	20
		16	10	± 0,2	3				
		12	8	± 0,2	2				
		10	6	± 0,1	2				
		8	5	± 0,1	1,5				
		6	3	± 0,1	1,5				
	30	25	20	± 0,2	2,5	35,5	57,5	44	22
		20	16	± 0,2	2				
		16	12	± 0,2	2				
		12	9	± 0,2	1,5				
		10	7	± 0,2	1,5				
		8	5	± 0,1	1,5				
		6	4	± 0,1	1				
	38	30	24	± 0,2	3	39,5	64,5	48,5	26
		25	20	± 0,2	2,5				
		20	16	± 0,2	2				
		16	12	± 0,2	2				
12		9	± 0,2	1,5					
10		7	± 0,2	1,5					
8		5	± 0,1	1,5					
6		4	± 0,1	1					

NOTE Working pressures correspond with 24° cone ends; see Table 1 or 2.

Dimensions in millimetres

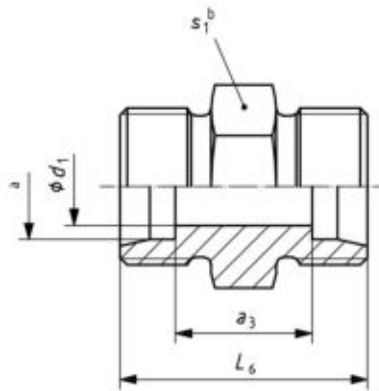

Figure 12 — Straight union connector (S)

Table 9 — Dimensions of straight union connectors

Series	Tube OD	d <sub>1</sub> ref.	L <sub>6</sub> ±0,3	S <sub>1</sub>	a <sub>3</sub> ref.
LL	4	3	20	9	12
	5	3,5	20	11	9
	6	4,5	20	11	9
	8	6	23	12	12
L	6	4	24	12	10
	8	6	25	14	11
	10	8	27	17	13
	12	10	28	19	14
	15	12	30	24	16
	18	15	31	27	16
	22	19	35	32	20
	28	24	36	41	21
	35	30	41	46	20
	42	36	43	55	21
S	6	4	30	14	16
	8	5	32	17	18
	10	7	32	19	17
	12	8	34	22	19
	16	12	38	27	21
	20	16	44	32	23
	25	20	50	41	26
	30	25	54	46	27
	38	32	61	55	29

Dimensions in millimetres

a Tube OD.  
b Width across flats.

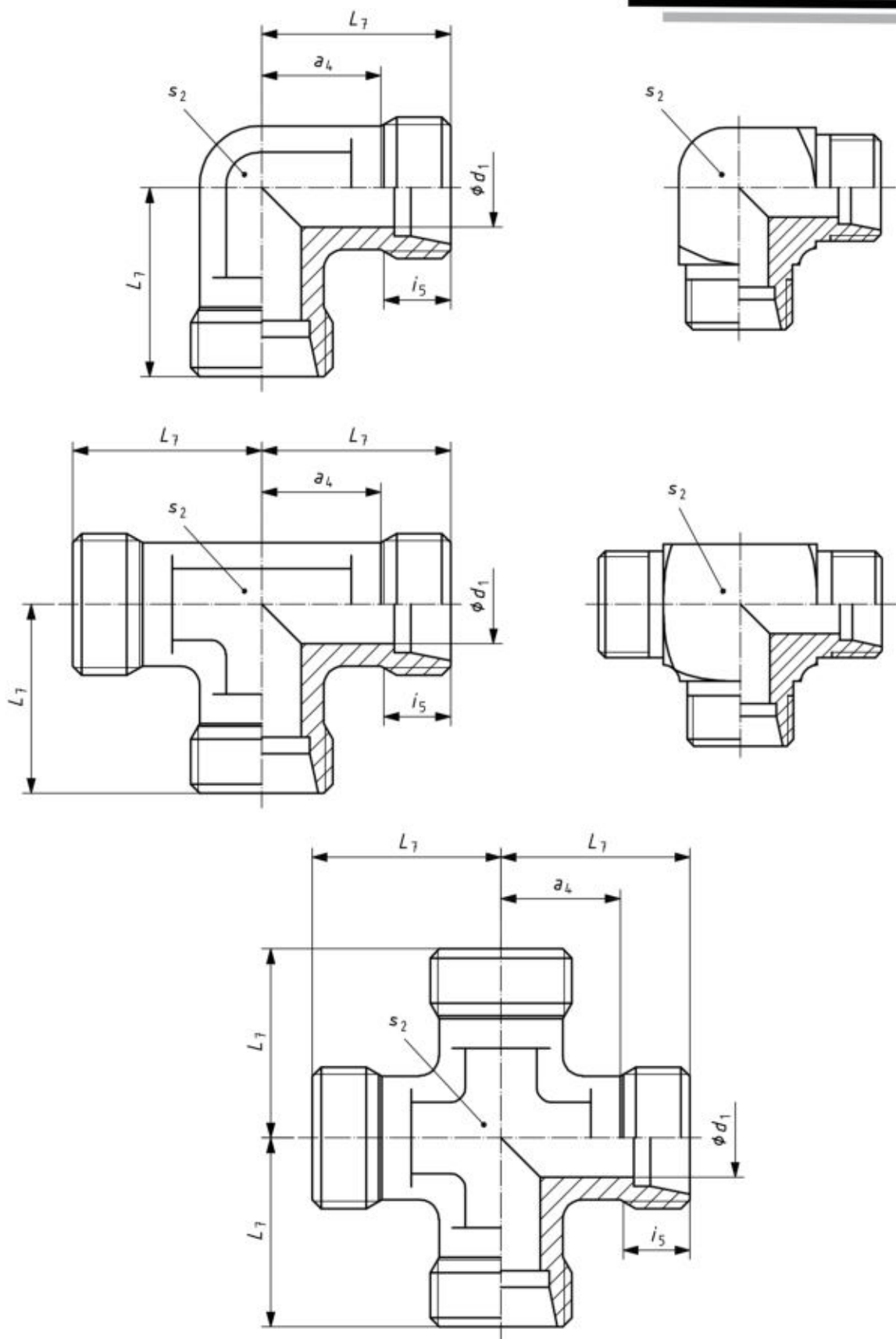

Figure 13 — Elbow (E), tee (T) and cross (K) union connector

Table 10 — Dimensions of elbow, tee and cross union connectors

Series	Tube OD	$d_1$	$i_5$	$L_7$	Forged connector	$S_2$	$a_4$
		ref.	min.	$\pm 0,3$	min.	Connector forged from barstock max.	ref.
LL	4	3	6	15	9	9	11
	5	3,5	6	15	9	11	9,5
	6	4,5	6	15	9	11	9,5
	8	6	7	17	12	12	11,5
L	6	4	7	19	12	12	12
	8	6	7	21	12	14	14
	10	8	8	22	14	17	15
	12	10	8	24	17	19	17
	15	12	9	28	19	—	21
	18	15	9	31	24	—	23,5
	22	19	10	35	27	—	27,5
	28	24	10	38	36	—	30,5
	35	30	12	45	41	—	34,5
	42	36	12	51	50	—	40
S	6	4	9	23	12	14	16
	8	5	9	24	14	17	17
	10	7	9	25	17	19	17,5
	12	8	9	29	17	22	21,5
	16	12	11	33	24	—	24,5
	20	16	12	37	27	—	26,5
	25	20	14	42	36	—	30
	30	25	16	49	41	—	35,5
	38	32	18	57	50	—	41

Dimensions in millimetres

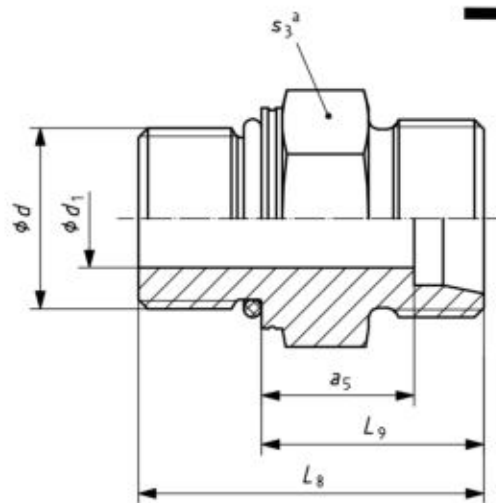

Figure 14 — Stud connector (SDS) for ports with O-ring sealing (type F) in accordance with ISO 6149-1

Table 11 — Dimensions of stud connectors for ports with O-ring sealing (type F) in accordance with ISO 6149-1

Series	Tube OD	d Thread <sup>a</sup>	d <sub>1</sub> ref.	L <sub>9</sub> ref.	L <sub>8</sub> ± 0,3	S <sub>3</sub>	a <sub>5</sub> ref.
L	6	M10 × 1	4	16,5	25	14	9,5
	8	M12 × 1,5	6	17	28	17	10
	10	M14 × 1,5	7	18	29	19	11
	12	M16 × 1,5	9	19,5	31	22	12,5
	15	M18 × 1,5	11	20,5	33	24	13,5
	18	M22 × 1,5	14	22	35	27	14,5
	22	M27 × 2	18	24	40	32	16,5
	28	M33 × 2	23	25	41	41	17,5
	35	M42 × 2	30	28	44	50	17,5
	42	M48 × 2	36	30	47,5	55	19
S	6	M12 × 1,5	4	20	31	17	13
	8	M14 × 1,5	5	22	33	19	15
	10	M16 × 1,5	7	22,5	35	22	15
	12	M18 × 1,5	8	24,5	38,5	24	17
	16	M22 × 1,5	12	27	42	27	18,5
	20	M27 × 2	15	31	49,5	32	20,5
	25	M33 × 2	20	35	53,5	41	23
	30	M42 × 2	25	37	56	50	23,5
	38	M48 × 2	32	41,5	63,5	55	26

<sup>a</sup> For further details, see ISO 6149-3 (regular length) for the L series and ISO 6149-2 for the S series.

Dimensions in millimetres



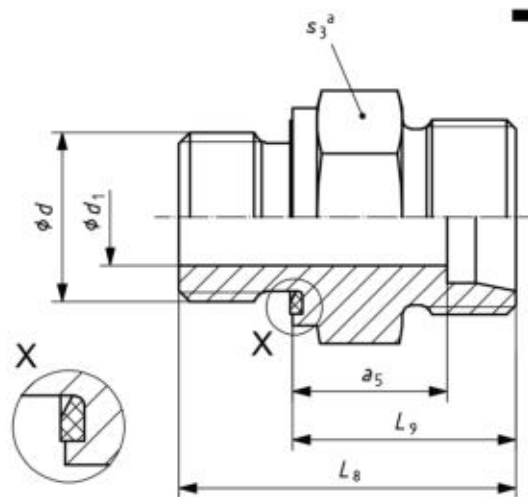

Figure 15 — Stud connector (SDS) for ports with elastomeric sealing (type E) and parallel threads

Table 12 — Dimensions of stud connectors for ports with elastomeric sealing (type E) and parallel threads

Series	Tube OD	Thread ISO 261 d	ISO 9974-2 <sup>a,b</sup>					ISO 1179-2 <sup>a,b</sup>					
			d <sub>1</sub> ref.	L <sub>9</sub> ref.	L <sub>8</sub> ± 0,3	S <sub>3</sub>	a <sub>5</sub> ref.	Thread ISO 228-1 d	d <sub>1</sub> ref.	L <sub>9</sub> ref.	L <sub>8</sub> ± 0,3	S <sub>3</sub>	a <sub>5</sub> ref.
L	6	M10 × 1	4	15,5	23,5	14	8,5	G 1/8 A	4	15,5	23,5	14	8,5
	8	M12 × 1,5	6	17	29	17	10	G 1/4 A	6	17	29	19	10
	10	M14 × 1,5	7	18	30	19	11	G 1/4 A	6	18	30	19	11
	12	M16 × 1,5	9	19,5	31,5	22	12,5	G 3/8 A	9	19,5	31,5	22	12,5
	15	M18 × 1,5	11	20,5	32,5	24	13,5	G 1/2 A	11	21	35	27	14
	18	M22 × 1,5	14	22	36	27	14,5	G 1/2 A	14	22	36	27	14,5
	22	M26 × 1,5	18	24	40	32	16,5	G 3/4 A	18	24	40	32	16,5
	28	M33 × 2	23	25	43	41	17,5	G 1 A	23	25	43	41	17,5
	35	M42 × 2	30	28	48	50	17,5	G 1 1/4 A	30	28	48	50	17,5
	42	M48 × 2	36	30	52	55	19	G 1 1/2 A	36	30	52	55	19
S	6	M12 × 1,5	4	20	32	17	13	G 1/4 A	4	20	32	19	13
	8	M14 × 1,5	5	22	34	19	15	G 1/4 A	5	22	34	19	15
	10	M16 × 1,5	7	22,5	34,5	22	15	G 3/8 A	7	22,5	34,5	22	15
	12	M18 × 1,5	8	24,5	36,5	24	17	G 3/8 A	8	24,5	36,5	22	17
	12	—	—	—	—	—	—	G 1/2 A	8	25	39	27	17,5
	16	M22 × 1,5	12	27	41	27	18,5	G 1/2 A	12	27	41	27	18,5
	16	—	—	—	—	—	—	G 3/4 A	12	29	45	32	20,5
	20	M27 × 2	16	31	47	32	20,5	G 3/4 A	16	31	47	32	20,5
	25	M33 × 2	20	35	53	41	23	G 1 A	20	35	53	41	23
	30	M42 × 2	25	37	57	50	23,5	G 1 1/4 A	25	37	57	50	23,5
38	M48 × 2	32	42	64	55	26	G 1 1/2 A	32	42	64	55	26	

<sup>a</sup> For further details on sealing, see the relevant part(s) of ISO 9974 and ISO 1179.

<sup>b</sup> For general applications only. For new designs in hydraulic fluid power applications, stud end dimensions shall be in accordance with the relevant part of ISO 6149.

Dimensions in millimetres

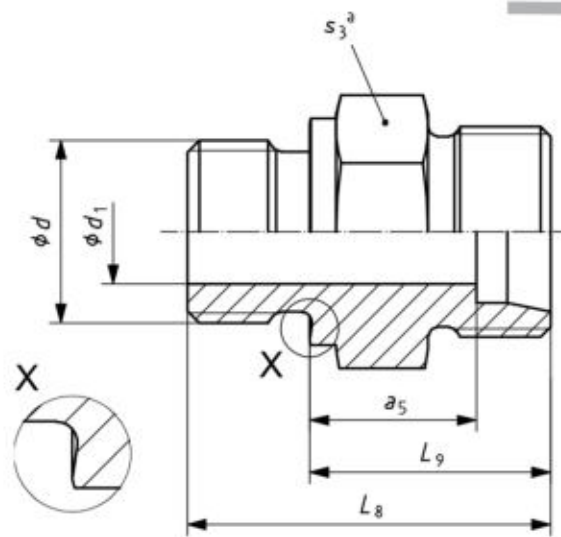

a Width across flats.

Figure 16 — Stud connector (SDS) for port with metal-to-metal sealing (type B) and parallel threads

**Table 13 — Dimensions for stud connectors for ports with metal-to-metal sealing (type B) and parallel threads**

Series	Tube OD	ISO 9974-3 <sup>a,b</sup>						ISO 1179-4 <sup>a</sup>					
		Thread ISO 261 d	d <sub>1</sub> ref.	L <sub>9</sub> ref.	L <sub>8</sub> ± 0,3	S <sub>3</sub>	a <sub>5</sub> ref.	Thread ISO 228-1 d	d <sub>1</sub> ref.	L <sub>9</sub> ref.	L <sub>8</sub> ± 0,3	S <sub>3</sub>	a <sub>5</sub> ref.
LL	4	M8 × 1	3	13,5	21,5	12	9,5	G 1/8 A	3	13,5	21,5	14	9,5
	5	M8 × 1	3	13,5	21,5	12	8	G 1/8 A	3	13,5	21,5	14	8
	6	M10 × 1	4	13,5	21,5	14	8	G 1/8 A	4	13,5	21,5	14	8
	8	M10 × 1	4,5	14,5	22,5	14	9	G 1/8 A	4,5	14,5	22,5	14	9
L	6	M10 × 1	4	15,5	23,5	14	8,5	G 1/8 A	4	15,5	23,5	14	8,5
	8	M12 × 1,5	6	17	29	17	10	G 1/4 A	6	17	29	19	10
	10	M14 × 1,5	7	18	30	19	11	G 1/4 A	6	18	30	19	11
	12	M16 × 1,5	9	19,5	31,5	22	12,5	G 3/8 A	9	19,5	31,5	22	12,5
	15	M18 × 1,5	11	20,5	32,5	24	13,5	G 1/2 A	11	21	32,5	27	14
	18	M22 × 1,5	14	22	36	27	14,5	G 1/2 A	14	22	36	27	14,5
	22	M26 × 1,5	18	24	40	32	16,5	G 3/4 A	18	24	40	32	16,5
	28	M33 × 2	23	25	43	41	17,5	G 1 A	23	25	43	41	17,5
	35	M42 × 2	30	28	48	50	17,5	G 1 1/4 A	30	28	48	50	17,5
	42	M48 × 2	36	30	52	55	19	G 1 1/2 A	36	30	52	55	19
S	6	M12 × 1,5	4	20	32	17	13	G 1/4 A	4	20	32	19	13
	8	M14 × 1,5	5	22	34	19	15	G 1/4 A	5	22	34	19	15
	10	M16 × 1,5	7	22,5	34,5	22	15	G 3/8 A	7	22,5	34,5	22	15
	12	M18 × 1,5	8	24,5	36,5	24	17	G 3/8 A	8	24,5	36,5	22	17
	12	—	—	—	—	—	—	G 1/2 A	8	25	39	27	17,5
	16	M22 × 1,5	12	27	41	27	18,5	G 1/2 A	12	27	41	27	18,5
	16	—	—	—	—	—	—	G 3/4 A	12	29	45	32	20,5
	20	M27 × 2	16	31	47	32	20,5	G 3/4 A	16	31	47	32	20,5
	25	M33 × 2	20	35	53	41	23	G 1 A	20	35	53	41	23
	30	M42 × 2	25	37	57	50	23,5	G 1 1/4 A	25	37	57	50	23,5
38	M48 × 2	32	42	64	55	26	G 1 1/2 A	32	42	64	55	26	

<sup>a</sup> For general applications only. For new designs in hydraulic fluid power applications, stud end dimensions shall be in accordance with the relevant part of ISO 6149.

Dimensions in millimetres

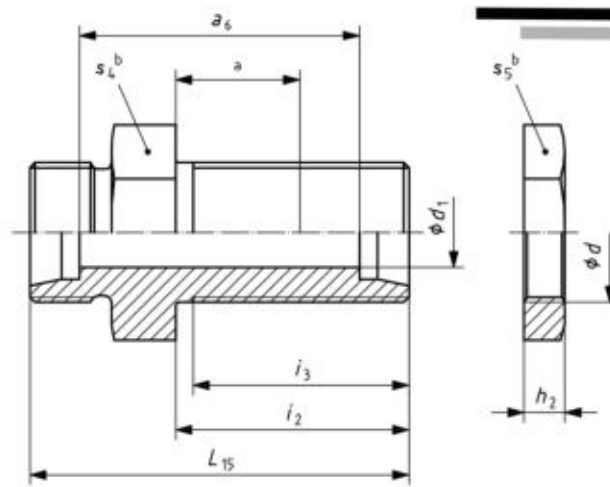

- a Maximum bulkhead thickness: 16 mm.  
 b Width across flats.

Figure 17 — Bulkhead straight connector (BHS) and locknut (LN)

Table 14 — Dimensions of bulkhead straight connectors and locknuts

Series	Tube OD	Bulkhead union connectors						Locknuts <sup>a</sup>		
		d <sub>1</sub> ref.	i <sub>3</sub> min.	i <sub>2</sub> ± 0,2	L <sub>15</sub> ± 0,3	S <sub>4</sub>	a <sub>5</sub> ref.	Thread d	S <sub>5</sub>	h <sub>2</sub> ± 0,2
L	6	4	30	34	48	17	34	M12 × 1,5	17	6
	8	6	30	34	49	19	35	M14 × 1,5	19	6
	10	8	31	35	52	22	38	M16 × 1,5	22	6
	12	10	32	36	53	24	39	M18 × 1,5	24	6
	15	12	34	38	57	27	43	M22 × 1,5	30	7
	18	15	36	40	61	32	46	M26 × 1,5	36	8
	22	19	37	42	66	36	51	M30 × 2	41	8
	28	24	38	43	69	41	54	M36 × 2	46	9
	35	30	42	47	76	50	55	M45 × 2	55	9
	42	36	42	47	77	60	55	M52 × 2	65	10
S	6	4	32	36	55	19	41	M14 × 1,5	19	6
	8	5	32	36	56	22	42	M16 × 1,5	22	6
	10	7	33	37	59	24	44	M18 × 1,5	24	6
	12	8	34	38	60	27	45	M20 × 1,5	27	6
	16	12	36	40	65	32	48	M24 × 1,5	32	7
	20	16	39	44	72	41	51	M30 × 2	41	8
	25	20	42	47	79	46	55	M36 × 2	46	9
	30	25	46	51	86	50	59	M42 × 2	50	9
	38	32	48	53	91	65	59	M52 × 2	65	10

<sup>a</sup> Locknuts for the following tube ODs in the L and S series share identical dimensions:

- L series tube OD 8 and S series tube OD 6;
- L series tube OD 10 and S series tube OD 8;
- L series tube OD 12 and S series tube OD 10;
- L series tube OD 22 and S series tube OD 20;
- L series tube OD 28 and S series tube OD 25;
- L series tube OD 42 and S series tube OD 38.

Dimensions in millimetres

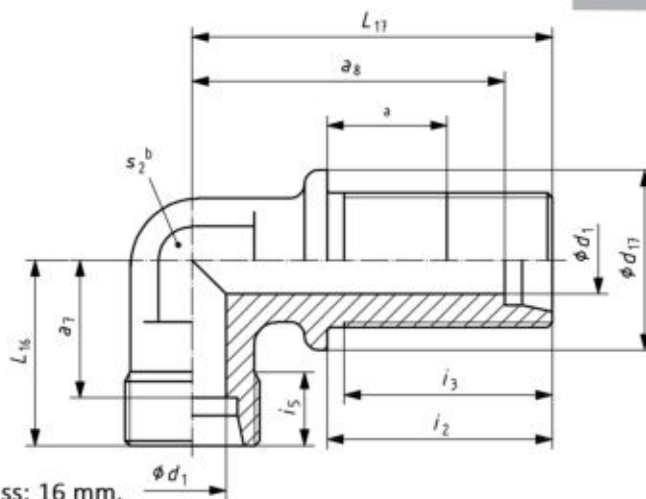

a Maximum bulkhead thickness: 16 mm.

b Width across flats.

Figure 18 — Bulkhead elbow (BHE)

Table 15 — Dimensions of bulkhead elbows

Series	Tube OD	d <sub>1</sub> réf.	d <sub>17</sub> ± 0,2	i <sub>5</sub> min.	i <sub>3</sub> min.	i <sub>2</sub> ± 0,2	L <sub>16</sub> ± 0,3	L <sub>17</sub> ± 0,3	s <sub>2</sub>	a <sub>7</sub> ref.	a <sub>8</sub> ref.
L	6	4	17	7	30	34	19	48	12	12	41
	8	6	19	7	30	34	21	51	12	14	44
	10	8	22	8	31	35	22	53	14	15	46
	12	10	24	8	32	36	24	56	17	17	49
	15	12	27	9	34	38	28	61	19	21	54
	18	15	32	9	36	40	31	64	24	23,5	56,5
	22	19	36	10	37	42	35	72	27	27,5	64,5
	28	24	42	10	38	43	38	77	36	30,5	69,5
	35	30	50	12	42	47	45	86	41	34,5	75,5
	42	36	60	12	42	47	51	90	50	40	79
S	6	4	19	9	32	36	23	53	12	16	46
	8	5	22	9	32	36	24	54	14	17	47
	10	7	24	9	33	37	25	57	17	17,5	49,5
	12	8	27	9	34	38	29	59	17	21,5	51,5
	16	12	30	11	36	40	33	64	24	24,5	55,5
	20	16	36	12	39	44	37	74	27	26,5	63,5
	25	20	42	14	42	47	42	81	36	30	69
	30	25	50	16	46	51	49	90	41	35,5	76,5
	38	32	60	18	48	53	57	96	50	41	80

Dimensions in millimetres

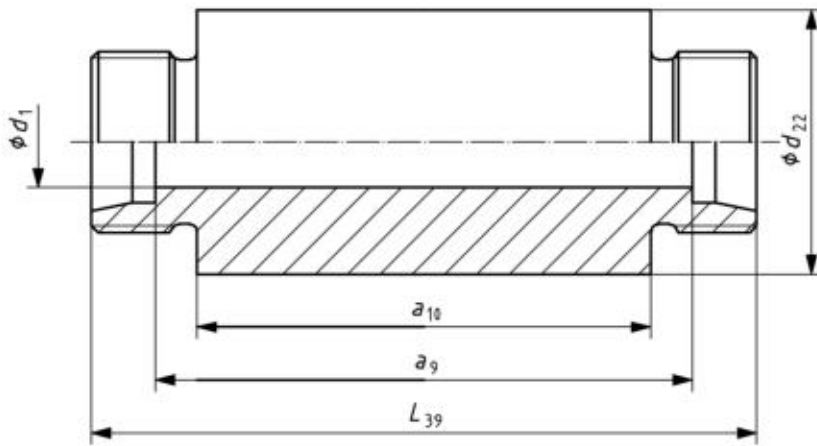
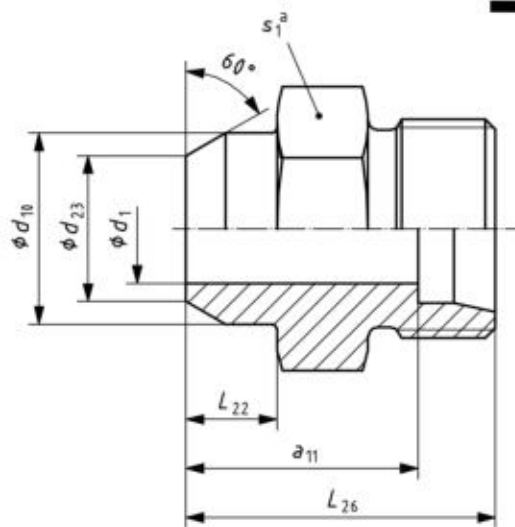

Figure 19 — Weld-in bulkhead straight connector (WDBHS)

Table 16 — Dimensions of weld-in bulkhead connectors

Series	Tube OD	$d_{22}$ $\pm 0,2$	$d_1$ ref.	$L_{39}$ $\pm 0,3$	$a_9$ ref.	$a_{10}$ ref.
L	6	18	4	70	56	50
	8	20	6	70	56	50
	10	22	8	72	58	50
	12	25	10	72	58	50
	15	28	12	84	70	60
	18	32	15	84	69	60
	22	36	19	88	73	60
	28	40	24	88	73	60
	35	50	30	92	71	60
42	60	36	92	70	60	
S	6	20	4	74	60	50
	8	22	5	74	50	50
	10	25	7	74	59	50
	12	28	8	74	59	50
	16	35	12	88	71	60
	20	38	16	92	71	60
	25	45	20	96	72	60
	30	50	25	100	73	60
	38	60	32	104	72	60

Dimensions in millimetres



a Width across flats.

Figure 20 — Weld-on straight connector (WDS)

Table 17 — Dimensions of weld-on straight connectors

Series	Tube OD	$d_{10}$ $\pm 0,2$	$d_{23}$ $\pm 0,2$	$d_1$ ref.	$L_{22}$ $\pm 0,2$	$L_{26}$ $\pm 0,3$	$S_1$	$a_{11}$ ref.
L	6	10	6	4	7	21	12	14
	8	12	8	6	8	23	14	16
	10	14	10	8	8	25	17	18
	12	16	12	10	8	25	19	18
	15	19	15	12	10	29	22	22
	18	22	18	15	10	31	27	23,5
	22	27	22	19	12	36	32	28,5
	28	32	28	24	12	38	41	30,5
	35	40	35	30	14	43	46	32,5
42	46	42	36	16	46	55	35	
S	6	11	6	4	7	26	14	19
	8	13	8	5	8	28	17	21
	10	15	10	7	8	30	19	22,5
	12	17	12	8	10	32	22	24,5
	16	21	16	12	10	35	27	26,5
	20	26	20	16	12	40	32	29,5
	25	31	24	20	12	44	41	32
	30	36	29	25	14	49	46	35,5
	38	44	36	32	16	54	55	38

Dimensions in millimetres

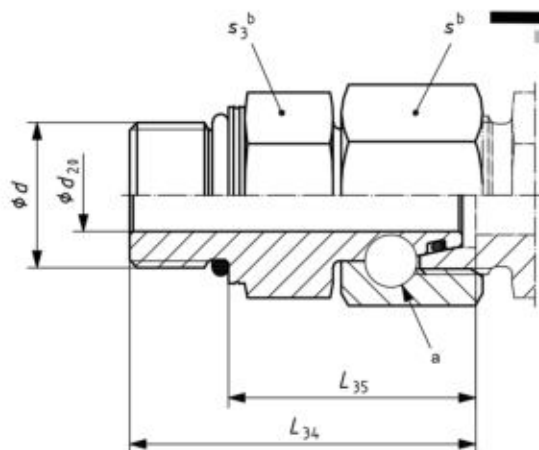

- a Method of swivel nut attachment is at the option of the manufacturer.  
b Width across flats.

Figure 21 — Swivel stud straight adapters with O-ring (SWOSDS) with stud end in accordance with ISO 6149-2 (S series) or ISO 6149-3 (L series)

Table 18 — Dimensions of swivel stud straight adapters with O-ring (SWOSDS) with stud end in accordance with ISO 6149-2 (S series) or ISO 6149-3 (L series)

Series	Tube OD	Thread d	$d_{20}$ min.	$L_{34} \pm 0,5$	$L_{35}$ ref.	$S_3$	S
L	6	M10 × 1	2,5	33	24,5	14	14
	8	M12 × 1,5	4	37,5	26,5	17	17
	10	M14 × 1,5	6	38,5	27,5	19	19
	12	M16 × 1,5	8	42	30,5	22	22
	15	M18 × 1,5	10	44	31,5	24	27
	18	M22 × 1,5	13	44,5	31,5	27	32
	22	M27 × 2	17	48,5	32,5	32	36
	28	M33 × 2	22	51	35	41	41 <sup>a</sup>
	35	M42 × 2	28	58,5	42,5	50	50
42	M48 × 2	34	64	46,5	55	60	
S	6	M12 × 1,5	2,5	38	27	17	17
	8	M14 × 1,5	4	40,5	29,5	19	19
	10	M16 × 1,5	6	44,5	32	22	22
	12	M18 × 1,5	8	48	34	24	24
	16	M22 × 1,5	11	52	37	27	30
	20	M27 × 2	14	61,5	43	32	36
	25	M33 × 2	18	66,5	48	41	46
	30	M42 × 2	23	70	51	50	50
	38	M48 × 2	30	81,5	60	55	60

<sup>a</sup> Alternative hex size: 46 mm.

Dimensions in millimetres



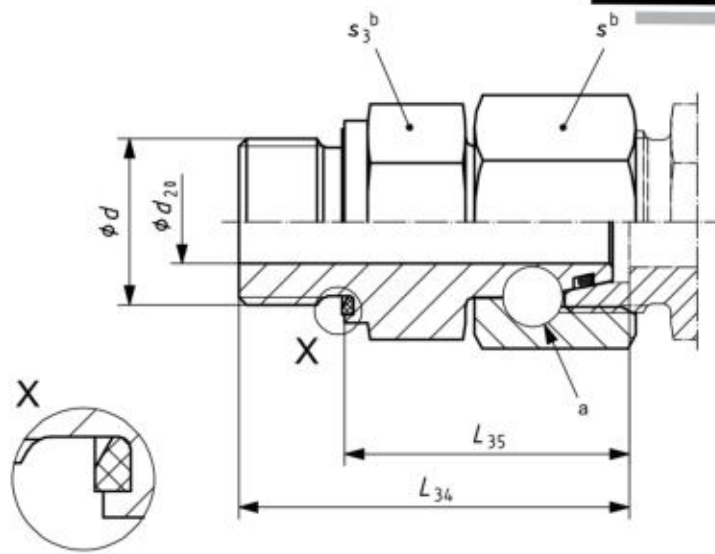

- a Method of swivel nut attachment is at the option of the manufacturer.
- b Width across flats.

Figure 22 — Swivel stud straight adapter with O-ring (SWOSDS) with stud end in accordance with ISO 1179-2 or ISO 9974-2

**Table 19 — Dimensions of swivel stud straight adapters with O-ring with stud end in accordance with ISO 1179-2 or ISO 9974-2**

Series	Tube OD	S	ISO 1179-2 stud end					ISO 9974-2 stud end				
			Thread ISO 228-1 d	d <sub>20</sub> min	L <sub>34</sub> ± 0,5	L <sub>35</sub> ref.	S <sub>3</sub>	Thread ISO 261 <sup>a</sup> d	d <sub>20</sub> min	L <sub>34</sub> ± 0,5	L <sub>35</sub> ref.	S <sub>3</sub>
L	6	14	G 1/8 A	2,5	32,5	24,5	14	M10 × 1	2,5	32,5	24,5	14
	8	17	G 1/4 A	4	41,5	29,5	19	M12 × 1,5	4	38,5	26,5	17
	10	19	G 1/4 A	6	39,5	27,5	19	M14 × 1,5	6	39,5	27,5	19
	12	22	G 3/8 A	8	46	34	22	M16 × 1,5	8	42,5	30,5	22
	15	27	G 1/2 A	10	46	32	27	M18 × 1,5	10	43,5	31,5	24
	18	32	G 1/2 A	13	45,5	31,5	27	M22 × 1,5	13	45,5	31,5	27
	22	36	G 3/4 A	17	48,5	32,5	32	M26 × 1,5	17	48,5	32,5	32
	28	41 <sup>b</sup>	G 1 A	22	53	35	41	M33 × 2	22	53	35	41
	35	50	G 1 1/4 A	28	62,5	42,5	50	M42 × 2	28	62,5	42,5	50
	42	60	G 1 1/2 A	34	68,5	46,5	55	M48 × 2	34	68,5	46,5	55
S	6	17	G 1/4 A	2,5	39	27	19	M12 × 1,5	2,5	39	27	17
	8	19	G 1/4 A	4	41,5	29,5	19	M14 × 1,5	4	41,5	29,5	19
	10	22	G 3/8 A	6	44	32	22	M16 × 1,5	6	44	32	22
	12	24	G 3/8 A	8	46	34	22	M18 × 1,5	8	46	34	24
	12	24	G 1/2 A	8	48,5	34,5	27	—	—	—	—	—
	16	30	G 1/2 A	11	51	37	27	M22 × 1,5	11	51	37	27
	16	30	G 3/4 A	11	55	39	32	—	—	—	—	—
	20	36	G 3/4 A	14	59	43	32	M27 × 2	14	59	43	32
	25	46	G 1 A	18	66	48	41	M33 × 2	18	66	48	41
	30	50	G 1 1/4 A	23	71	51	50	M42 × 2	23	71	51	50
	38	60	G 1 1/2 A	30	82	60	55	M48 × 2	30	82	60	55

<sup>a</sup> For ISO 261 threads, connectors complying with Figure 21 and Table 18 (ISO 6149-2 and ISO 6149-3 stud ends) are preferred.

<sup>b</sup> Alternative hex size: 46 mm.

Dimensions in millimetres

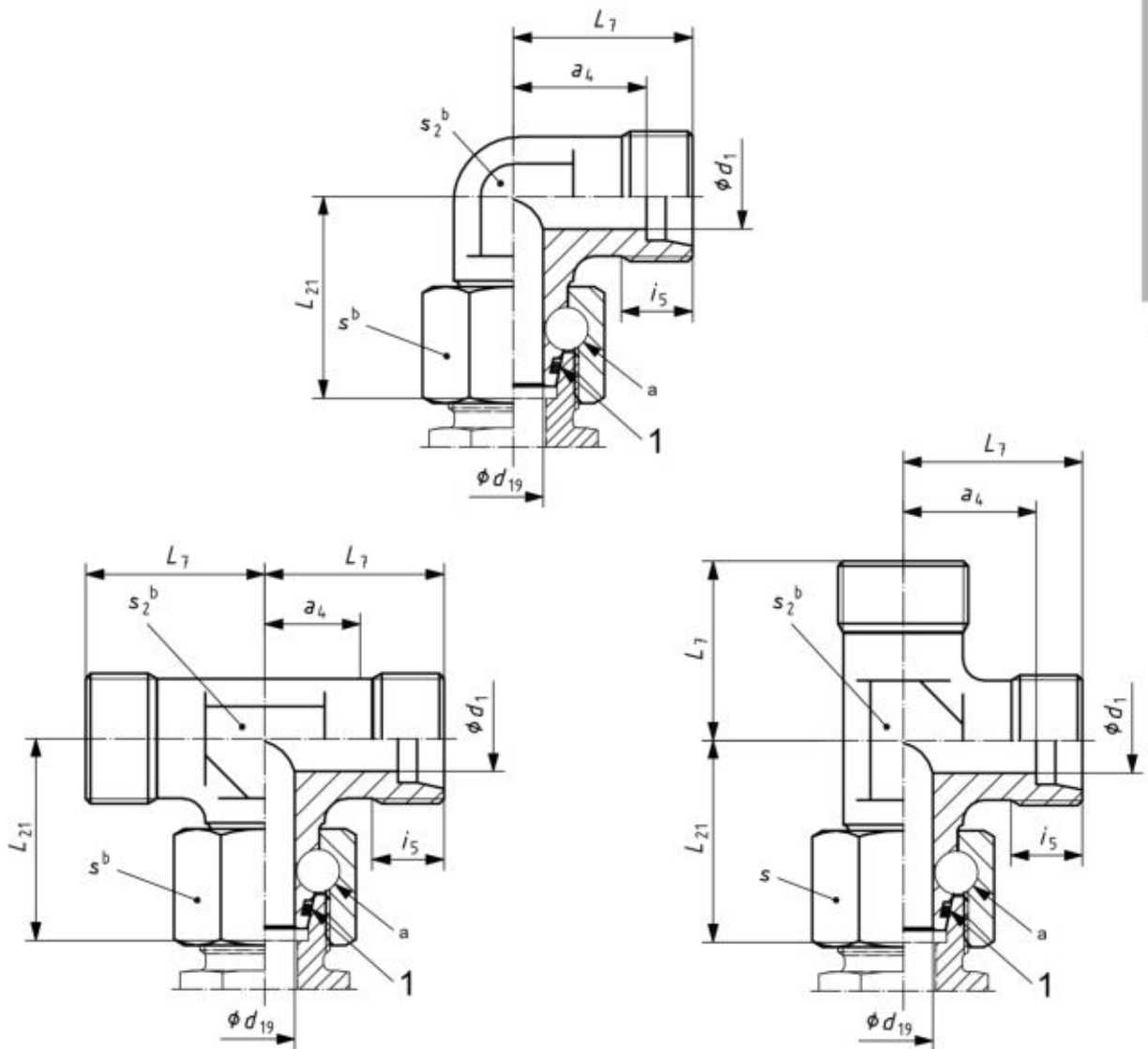

### Key

1 O-ring

a Method of swivel nut attachment is at the option of the manufacturer.

b Width across flats.

Figure 23 — Swivel elbow (SWOE), branch tee (SWOBT) and run tee (SWORT) with O-ring

Table 20 — Dimensions of swivel elbows, swivel branch tees and swivel run tees with O-ring

Series	Tube OD	d <sub>1</sub>	d <sub>19</sub>	L <sub>21</sub>	L <sub>7</sub>	a <sub>4</sub>	i <sub>5</sub>	S <sub>2</sub>		S
		ref.	min	± 0,5	± 0,3	ref.	min.	Forged connector min.	Connector machined from barstock max.	
L	6	4	2,5	26	19	12	7	12	—	14
	8	6	4	27,5	21	14	7	12	14	17
	10	8	6	29	22	15	8	14	17	19
	12	10	8	29,5	24	17	8	17	19	22
	15	12	10	32,5	28	21	9	19	—	27
	18	15	13	35,5	31	23,5	9	24	—	32
	22	19	17	38,5	35	27,5	10	27	—	36
	28	24	22	41,5	38	30,5	10	36	—	41 <sup>a</sup>
	35	30	28	51	45	34,5	12	41	—	50
	42	36	34	56	51	40	12	50	—	60
S	6	4	2,5	27	23	16	9	12	14	17
	8	5	4	27,5	24	17	9	14	17	19
	10	7	6	30	25	17,5	9	17	19	22
	12	8	8	31	29	21,5	9	17	22	24
	16	12	11	36,5	33	24,5	11	24	—	30
	20	16	14	44,5	37	26,5	12	27	—	36
	25	20	18	50	42	30	14	36	—	46
	30	25	23	55	49	35,5	16	41	—	50
	38	32	30	63	57	41	18	50	—	60

<sup>a</sup> Alternative hex size: 46 mm.

Dimensions in millimetres

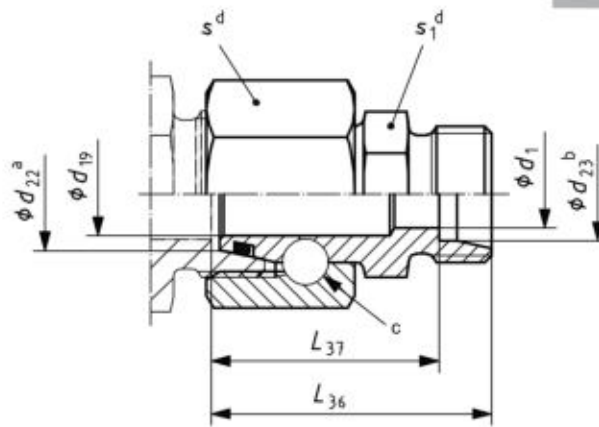

- a Tube OD ( $d_{22}$ ).
- b Tube OD ( $d_{23}$ ).
- c Method of swivel nut attachment is at the option of the manufacturer.
- d Width across flats.

Figure 24 — Reducing swivel straight adapter with O-ring (RDSW)

Table 21 — Dimensions of reducing swivel straight adapters with O-ring

Series	Tube OD		$d_1$ ref.	$d_{19}$ min.	$L_{36}$ $\pm 0,5$	$L_{37}$ ref.	$s_1$	S
	$d_{22}$ ref.	$d_{23}$ ref.						
L	8	6	4	4	30,5	23,5	12	17
	10	6	4	6	32	25	14	19
		8	6	6	32	25		
	12	6	4	8	32	25	17	22
		8	6	8	32	25		
		10	8	8	33	26		
	15	10	8	10	36,5	29,5	19 (22)	27
		12	10	10	36,5	29,5		
	18	15	12	12	37	30	24	32
	22	15	12	17	41	34	27	36
		18	15	17	41	33,5		
	28	15	12	22	43	36	32 (36)	41 (46)
		18	15	22	43	35,5		
		22	19	22	45	37,5		
	35	15	12	28	46	39	41 (46)	50
		18	15	28	46	38,5		
		22	19	28	48	40,5		
		28	24	28	48	40,5		
	42	15	12	34	49,5	42,5	50	60
		18	15	34	49,5	42		
22		19	34	51,5	44			
28		24	34	51,5	44			
35		30	34	53,5	43			

Dimensions in millimetres

Table 21 — Dimensions of reducing swivel straight adapters with O-ring (continued)

Series	Tube OD		d <sub>1</sub> ref.	d <sub>19</sub> min.	L <sub>36</sub> ± 0,5	L <sub>37</sub> ref.	s <sub>1</sub>	s
	d <sub>22</sub> ref.	d <sub>23</sub> ref.						
S	8	6	4	4	34	27	14	19
	10	6	4	6	34,5	27,5	17	22
		8	5	6	34,5	27,5		
	12	6	4	8	37	29	19	24
		8	5	8	37	29		
		10	7	8	37	29,5		
	16	6	4	11	39	32	22	30
		8	5	11	39	32		
		10	7	11	39	31,5		
		12	8	11	39	31,5		
	20	6	4	14	43	36	27	36
		8	5	14	43	36		
		10	7	14	43	35,5		
		12	8	14	43	35,5		
		16	12	14	45	36,5		
	25	6	4	18	45,5	38,5	32 (36)	46
		8	5	18	45,5	38,5		
		10	7	18	45,5	38		
		12	8	18	45,5	38		
		16	12	18	47,5	39		
		20	16	18	49,5	39		
	30	6	4	23	51	44	41	50
		8	5	23	51	44		
		10	7	23	51	43,5		
12		8	23	51	43,5			
16		12	23	53	44,5			
20		16	23	55	44,5			
25		20	23	57	45			
S	38	6	4	30	54,5	47,5	50	60
		8	5	30	54,5	47,5		
		10	7	30	54,5	47		
		12	8	30	54,5	47		
		16	12	30	56,5	48		
		20	16	30	58,5	48		
		25	20	30	60,5	48,5		
		30	25	30	62,5	49		

Dimensions in millimetres

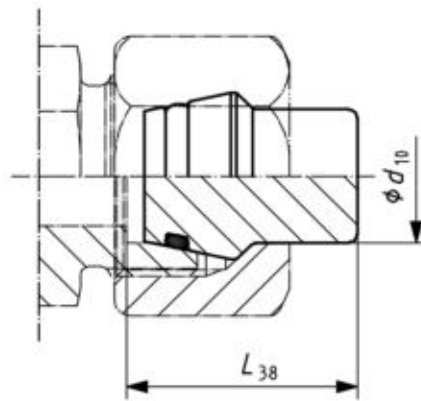

Figure 25 — Plug with O-ring (PL)

Table 22 — Dimensions of plugs with O-ring

Series	Tube OD $d_{10}$	$L_{38}$ $\pm 0,5$
L	6	19,0
	8	19,0
	10	20,5
	12	21,0
	15	21,0
	18	23,5
	22	26,0
	28	26,5
	35	32,0
	42	32,5
S	6	19,0
	8	19,0
	10	21,0
	12	21,5
	16	25,0
	20	30,5
	25	32,5
	30	35,5
	38	40,5

Dimensions in millimetres

# Bibliography

- [1] ISO 228-2, Pipe threads where pressure-tight joints are not made on the threads — Part 2: Verification by means of limit gauges
- [2] ISO 286-1, Geometrical product specifications (GPS) — ISO code system for tolerances of linear sizes — Part 1: Basis of tolerances, deviations and fits1)
- [3] ISO 286-2, ISO system of limits and fits — Part 2: Tables of standard tolerance grades and limit deviations for holes and shafts
- [4] ISO 1179-3, Connections for general use and fluid power — Ports and stud ends with ISO 228-1 threads with elastomeric or metal-to-metal sealing — Part 3: Light-duty (L series) stud ends with sealing by O-ring with retaining ring (types G and H)
- [5] ISO 4397, Fluid power systems and components — Connectors and associated components — Nominal outside diameters of tubes and nominal inside diameters of hoses
- [6] ISO 4399, Fluid power systems and components — Connectors and associated components — Nominal pressures



# Products



**Flange Adapter**



**Pipe Fitting**



**Flare Fitting**



**Valve Manifold**



**Thermowells**



**Check Valve**



**Tube Fitting**



**Needle Valve**



**Weld Fitting**



**Swivel Adapter**



**High Pressure**



**Gauge Root**



## **BE-LOK INSTRUMENT FITTING INC**

Corporate Address : #V-13 A, Qureshi Estate, Zilu Parab Road,  
Near Chinchoti Naka, Village-Chinchoti, Naigaon,  
District Palghar (401208), Maharashtra, India.

Tel : +91-9785579843,  
+91-9156629351

Email : [sales@be-lok.com](mailto:sales@be-lok.com), [info@be-lok.com](mailto:info@be-lok.com)  
Website : [www.be-lok.com](http://www.be-lok.com)